

Table of Contents

Table of Contents	1
MECHANICAL	1
A. Design Criteria and Campus and Power Plant Central Utilities	1
Programming.....	1
Design Criteria	1
Inter-discipline Coordination.....	2
Operational Constraints	3
Construction Requirements	3
Renovation and Demolition	3
Power Plant Central Utilities	3
Steam and Steam Condensate	4
Central Cooling Water (CCW).....	4
Compressed Air	5
Installation, Fabrication and Construction	6
Heating Ventilation and Air Conditioning	8
B. Building Chilled Water Systems	8
Programming.....	8
Design Criteria	8
CCW-CPP Design Criteria.....	10
CCW-WCUP Design Criteria	10
CCW Header at Building	11
Installation, Fabrication and Construction	11
C. Building Steam and Condensate	13
Design Criteria	13
Products, Material and Equipment	13
Installation, Fabrication, and Construction	14
D. Coils and Filters	15
Coils	15
Filters.....	15
Products, Material and Equipment	15
Installation, Fabrication and Construction	15
E. Computer Server Rooms	17
Basis of Design.....	17
F. Refrigeration	18
Design Criteria	18
Products, Material and Equipment	20
Installation, Fabrication and Construction	20

G. Ductwork and Duct Pressure Testing	21
Design Criteria	21
Supply, Return and Non Fume Exhaust Ductwork	21
Dampers	21
Pressure Relief Doors or Panels	22
Mounting.....	22
Renovation and Expansion Projects	22
Fan-powered Zone Air Terminal Boxes	23
Smoke/Fire Dampers.....	23
Access Doors and Panels	23
Hospitals, Labs, and Animal Holding Facilities Pressure Relationships	24
Construction Submittals.....	24
Products, Material and Equipment	24
Installation, Fabrication and Construction	25
H. Hydronic Heating	29
Programming.....	29
Design Criteria	29
Products, Material and Equipment	29
Installation, Fabrication and Construction	30
I. Ventilation Design Criteria	31
Design Criteria	31
Plumbing	33
J. Compressed Air, Vacuum, Natural Gas & Nitrogen	33
Design Criteria	33
Installation, Fabrication and Construction	33
K. Potable and Nonpotable Water	34
Design Criteria	34
Water Filter Header	35
Typical Building Water Header.....	36
L. RO/DI	37
Design Criteria	37
Installation, Fabrication and Construction	37
M. Waste and Drains	38
Design Criteria	38
Installation, Fabrication and Construction	38
N. Water Reclaim System	39
Water Reclaim and Rainwater Harvesting	39
Cistern	39
Piping and Pumping.....	39
Filtration and Water Treatment.....	39
Reclaimed Water Usage	39

Specific Mechanical Systems	40
O. Commissioning	40
Background	40
Design Criteria	40
Construction Submittals	42
P. Environmental Control Systems	43
Environmental Control Systems Overview	43
Approved Manufacturers (no substitutions):.....	43
Hardware and Software	43
Graphic Display.....	43
Interface	44
Interfacing the DDC with Equipment Built-In Controls	44
Interfacing the DDC with Fire Alarm	44
Interfacing the DDC with Emergency Power	44
Standby Power	45
Renovation and remodel projects.....	45
Sensors	45
Deliverables.....	45
Q. Identification	46
Products, Material and Equipment	46
Installation, Fabrication and Construction	46
R. Metering and Gauges	48
Meter Installation.....	48
Gauge Installation	48
Pipe and Fittings.....	48
Pipe Accessories	48
Duct Accessories.....	48
Mechanical Meter Profile Report.....	50
S. Motors and VFDs	54
Electric Motors	54
Variable Frequency Drives.....	54
Installation, Fabrication and Construction	55
T. Noise and Vibration Control	57
Design Criteria	57
Products, Material and Equipment	57
Installation, Fabrication and Construction	58
U. Piping, Valve Pressure Testing and Accessories	59
Design Criteria	59
Design Evaluation.....	61
Products, Material and Equipment	61
Installation, Fabrication and Construction	69

V. Pumps	72
Basis of Design	72
Design Criteria	72
Products, Material and Equipment	72
Installation, Fabrication and Construction	73
W. Testing, Adjusting and Balancing	74
Design Criteria	74
Construction Submittals	74
X. Water Treatment and Flushing	76
Design Criteria	76
Installation, Fabrication and Construction	76
Preferred Vendors table	Appendix

Mechanical

A. Design Criteria and Campus and Power Plant Central Utilities

Programming

1. Provide equipment access pathways large enough to allow for the removal of coils and other large pieces of equipment. Identify these areas on the design drawings.
2. Include an evaluation for building system renovation projects which describes the condition of the building systems, variances from present codes, and identifies spare system capacity or system deficiencies and opportunities for improving energy efficiency. The design team's mechanical, electrical, civil, structural, and architectural disciplines participate jointly in this evaluation.

Design Criteria

1. Provide the basis of design including design parameters and analyses for the following:
 - a. Connection to existing utility distribution systems, including capacity and location,
 - b. Temporary construction water and sewer point of service,
 - c. Distribution concepts including piping and ductwork,
 - d. Load calculations for campus utilities,
 - e. Seismic bracing for mechanical equipment, piping and ductwork,
 - f. Special systems design (research and diagnostic equipment, and other equipment and designs not specifically covered by the FDS),
 - g. Control systems and indoor environmental monitoring,
 - h. Indoor dry bulb temperature,
 - i. Indoor relative humidity,
 - j. Outdoor dry bulb temperature,
 - k. Outdoor wet bulb temperature,
 - l. Occupancy, hours, and degree of activity,
 - m. Ventilation – recirculation and outside air,
 - n. Internal loads,
 - o. Special loads,
 - p. Insulating R-values for roof, wall, glass, etc.,
 - q. Percentage of glass – fenestration,
 - r. Type of glass, including coatings and solar coefficients,
 - s. Building pressurization and infiltration,
 - t. Building mass,
 - u. Code requirements and impact on criteria,
 - v. Air quality design criteria, i.e. ASHRAE 62, current edition
 - w. Noise criteria,
 - x. Building energy consumption and energy source,
 - y. Life cycle cost analysis for mechanical systems.

- z. Sustainability,
 - aa. Maintainability.
 - bb. Redundancy
 - cc. Future Capacity
 - dd. Standby Power
 - ee. Fire and Life Safety
2. Design systems and components with maximum reliability, maximum flexibility, and minimum operation and maintenance cost. Give full consideration for future system alterations with a minimum of system shutdowns. Accomplish preventive maintenance without a major building shutdown. Maintenance accessibility is very important. Meet current regulations for worker safety, including fall protection.
 3. Since laboratory buildings need periodic renovation to keep up with changing technology, divide the building up into lab modules. These lab modules are a basis for HVAC and plumbing zoning.
 4. Provide isolation valves and devices for each utility serving each lab. Down feed all mechanical systems except the waste lines to minimize the number of floor penetrations.
 5. Coordinate mechanical equipment located on the roof with the Architect. Minimize the number of roof penetrations.
 6. Provide an acceptable means of accessing major equipment that needs to be maintained on a regular basis without the use of a portable ladder.
 7. Provide access with platform for shafts that contain systems that require periodic maintenance, repair, or replacement, e.g. valves, dampers, and actuators. Provide accessibility where space is required for future mechanical equipment. Provide access through access doors or removable walls and space within the shafts. Sheet rock walls are considered removable. Accessible shafts are preferred over removable walls. Coordinate access method and platform requirements with Architect.
 8. Mount equipment, e.g. fans and pumps, on a 4-inch thick concrete pad secured to structural slab. Size concrete pads larger than equipment. Extend the pad at least ten times the diameter of the mounting bolts past the equipment. Coordinate with Structural Engineer for final design.
 9. See Architectural Finishes section for coating over entire mechanical room floor, including over housekeeping pads under air handling units, etc.
 10. Provide galvanized schedule 40 pipe sleeves or manufactured through-penetration firestop devices for all piping penetrations through concrete and masonry. Coordinate with architectural and structural for location and installation.

Inter-discipline Coordination

1. Coordinate the mechanical work with other disciplines to define the work and responsibilities of the Mechanical Contractor. Because of the space taken up by the mechanical equipment coordinate the required infrastructure with all elements of the building to include architectural, structural and electrical. In many cases, the mechanical and electrical system space requirements necessitate changes to the floor plans, building sections, and exterior elevations, if not properly coordinated at the onset.
2. Align the mechanical shafts to minimize offsets.

3. Coordinate between the Mechanical Engineer and Electrical Engineer for equipment motors, motor starters, disconnect switches, thermal overload switches, variable frequency drives, and mechanical controls for all mechanical equipment including AHUs, exhaust fans, and pumps.

Operational Constraints

1. Sustainability, operability and maintainability are key elements in the evaluation of the Technical Program and Schematic Design. General use buildings are operated to match occupancy and are normally shut down during nights (10pm to 6am), weekends and holidays. Libraries usually have extended schedules. Laboratory buildings normally run continuously to maintain a safe working environment 24 hours per day. Evaluate on a building-by-building basis; to allow a more efficient operation.
2. In remodel or renovation projects, shutdowns of existing utilities and services may be necessary. These shutdowns may have to occur after normal working hours to prevent interruption of critical operations. Temporary utilities may be necessary to maintain service to critical loads in laboratories and hospital health care areas and to refrigeration equipment.
3. Locate equipment, valves, and accessories above ceilings such that they can be readily accessed within arm's reach by a person standing no higher than the second highest step on a stepladder of a height that fits below the ceiling. Coordinate ladder placement to avoid interference from casework, lab benches, sinks, adjacent walls, or lab equipment. Give consideration to ceiling tiles immovable due to sprinkler heads, light fixtures, or other ceiling mounted devices.

Construction Requirements

1. Include a statement in the specifications that all components of the ventilation system (e.g. fan, duct, insulation, sound attenuators, terminal boxes, etc.) must be kept clean and dry as manufactured, delivered, stored and installed before operating the HVAC system. At the University of Washington Medical Center and specific animal care facilities, confirm if isopropyl alcohol wipe-down is required at all air handling equipment prior to installation.

Renovation and Demolition

1. The abandonment of existing equipment and material in place is not acceptable. Conserve space as much as possible.
2. The correction of existing mechanical problems and removal of abandoned mechanical equipment, while maintaining the operation of the building, all need to be addressed in the contract documents.

Power Plant Central Utilities

Distributed utilities are generated at the Central Power Plant (CPP) and the West Campus Utility Plant (WCUP). Distributed mechanical utilities at the CPP include steam and steam condensate, chilled water, and compressed air. The WCUP generates chilled water only.

Steam and Steam Condensate

Steam is distributed from the Central Power Plant (CPP) to the campus buildings through the utility tunnel system. The primary use of the steam is for campus building heat. Other uses are Power Plant boiler auxiliary equipment, building service water heating, kitchens, humidity control and sterilization at the UW Medical Center and campus laboratories.

Steam is generated at 425 psi at the Power Plant to operate the turbine generator. Steam is extracted from the Power Plant steam turbine and distributed to the campus at 185 psi. The Power Plant also generates steam at 185 psi to supplement the steam provided by the turbine. Exhaust steam from the steam turbine at 10 psi is also distributed to the campus.

Each of the two steam pressure distribution systems is provided in a looped tunnel configuration as much as practical to provide service to the buildings. The loop configuration makes it possible to shutdown steam service from one side of the loop for maintenance or new construction connections while the other side of the loop remains in service to the buildings.

High temperature condensate is collected throughout the utility tunnel system where the 185 psi steam releases its energy and flashes. Low pressure steam generated from flashing is piped to the 10 psi steam system in the tunnel or in nearby buildings.

After the steam releases its energy and transitions into condensate, it is collected as much as feasible. The condensate is either pumped or returned by gravity to the Power Plant for steam generation.

Central Cooling Water (CCW)

Two utility plants supply CCW to the system:

The Central Power Plant (CPP) generates nominal 12,000-tons cooling capacity using five 2,000-ton centrifugal chillers, one 1,000-ton centrifugal chiller, and one 1,000-ton absorption chiller plus associated cooling towers and pumps. CCW-CPP operates seasonally from approximately early April through early October. CCW-CPP provides a source of higher temperature unconditioned condensing water during winter months when the chillers are off.

West Campus Utility Plant (WCUP) provides process cooling water with 3000-tons N+1 cooling capacity (with space for future build out up to 9000-tons N+1) using three 1,500-ton centrifugal chillers plus associated cooling towers and pumps. WCUP operates year around.

Each plant delivers central cooling water to interconnected distribution piping with manual isolation valves for separating the plant's service sections.

Delta P Valves are required at each cooling coil or heat exchanger to set flow limit to maintain high return differential temperatures to the chillers. No substitution allowed.

Compressed Air

Compressed air is generated at the Central Power Plant (CPP) by three air compressors with a total nominal capacity of 6000 ACFM. The compressed air is distributed as a central utility from the CPP to campus buildings primarily through the tunnel system. The distribution service pressure is 100 psig. Before the compressed air leaves the Plant it passes through a desiccant air dryer system to a dew point of 40 degrees F. If drier air is required for use in the buildings then an air drier should be provided in the building.

The primary use of compressed air on campus is for the building environmental control systems. There are many campus buildings with pneumatic controls that are still in operation. Many of the new and renovated buildings have been outfitted with Direct Digital Control (DDC) systems. These buildings with DDC systems still utilize compressed air for operating large pneumatic control valves and damper actuators. Other uses for compressed air on campus include fire protection dry pipe systems, fire smoke damper actuators, automatic door openers, and teaching and research laboratories.

Air Handlers

1. Include double-walled panels in air handlers with a minimum of 2 inches of fiberglass insulation, 16 gauge exterior galvanized steel; and 22 gauge internal galvanized steel perforated except downstream of cooling coils and in outside air intakes.
 - a. Floor: non-skid floor that extends up the walls to prevent leakage in the event of water accumulation.
 - b. For access doors, use the same metal gauges and insulation levels as are specified for the rest of unit.
 - c. Downstream from cooling coils, double-walled internal duct insulation with a solid metal surface exposed to the air stream is required.
2. Provide galvanized angle iron bracing inside plenums.
3. Provide access doors to each area between the coils, filters and fan. The access between the coils, filters and fan must be a minimum of 18 inches (preferably 24 to 36 inches).
4. Fan array must include individual backdraft dampers at each fan.

Fume Hood Fans

1. Provide access for fan maintenance.
2. Mount the fan with vibration isolators.
3. Installing fans in a penthouse is preferred. Provide weather protection for fans installed outdoor.
4. Locate the fan as the last element of the system to assure that the ductwork throughout the building is under negative pressure.
5. Install fans to be readily accessible for maintenance and inspection without entering the plenum. If exhaust fans are located inside a penthouse, consider the ventilation needs of maintenance workers.

6. Discuss fire alarm interlocks to fume exhaust fans and standby power requirements with EH&S and Engineering Services.
7. Specify fume exhaust fans with minimum two belt sheaves.
8. Provide ball-type fan bearings (selected for extended life), lubricated with grease fittings extended through fan casing for easy access.
9. Provide each fan drive with an easily removable guard assembly protecting drive belts and shaft, with access for tachometer use.
10. Specify all belt guards to allow visual inspection.

Fume Exhaust Fans

1. Provide fans with the following:
 - a. Outboard "split" bearings,
 - b. Shaft seal,
 - c. An access door,
 - d. Multiple 150 percent rated belt drive. In designing for explosion and fire control, provide fans with non-sparking construction and non-conductive V-belt drives.
2. Provide chemical resistant fan system.
3. Weld or permanently seal fan housing to avoid air leakage from the wheel shaft and discharge.
4. Fume exhaust fans to have arrangement 1 or 9, overhung wheel type with bearings outside air stream. Fans to have two bearings; split-case with split inner and outer races and cage.
5. Choose fan type as follows:
 - a. Use straight-radial fans for systems handling moderate to heavy quantities of particulate matter in air.
 - b. Use backward-inclined fans for systems handling relatively clean (low particulate) air.

Perchloric Acid Hood

1. Provide an induction type fan for perchloric acid hoods.
2. Provide perchloric acid systems, including duct fans and hood, with an internal wash-down system that meets the following requirements:
 - a. Design the perchloric acid fume hood system to provide as complete a wash-down with all ductwork at 45 degrees or less from vertical to drain back to the fume hood.
 - b. Provide fan casings and hood bottoms with continuous gravity drainage to the acid resistant waste.
 - c. The wash down system to include a manual valve located adjacent to the fume hood.
 - d. Prior to substantial completion, testing of the wash-down system to be witnessed and approved by Owner's witness and EH&S.

Installation, Fabrication and Construction

1. During storage, transport, and installation prior to start-up, cover the air handlers with plywood and/or plastic as necessary to keep them dry, clean, and protected from damage. Provide

heaters and/or dehumidifiers if necessary to prevent condensation inside air handlers prior to start-up. Provide temperature/humidity data loggers in units in transit and during storage. Air handlers with insulation that has been wet are unacceptable.

2. Thoroughly clean equipment casings of debris and small particles of rubbish and dust before installing and making final duct connections.
3. Do not start the fans until the Owner has approved the level of cleanliness of the air distribution system. Provide full access to the system for the inspection of cleanliness prior to start-up.
4. The preferred fan design is single inlet, single width centrifugal type with backward inclined airfoil blades; however, utilization of airfoils, propellers, and duct axial flow fans is acceptable where appropriate.
5. Do not provide VFDs on manifolded fume exhaust systems unless a minimum of 2500 fpm exit stack velocity can be maintained. Refer to section Mechanical – Testing, Adjusting, and Balancing for balancing information related to VFDs.
6. Provide rigid structural steel base for both fan and motor with slide rails for drive adjustment. Hinged motor bases are not acceptable.
7. Avoid operating HVAC systems prior to the completion of construction except where flushing of the building is necessary to comply with LEED requirements.
8. After construction dirt has been removed from the building, provide new filters for permanent locations.
9. Indicate the required filter removal and equipment access space on the contract documents.

Heating Ventilation and Air Conditioning

B. Building Chilled Water Systems

Building Chilled Water applies to one or more of the following systems:

- Central Cooling Water (CCW)
- Process Chilled Water
- Environmental Chilled Water

Programming

1. Some lab equipment may require a decoupled primary/secondary loop to accommodate high pressure drops and internal condensation.
2. Give special consideration to the location of cooling towers with respect to contamination of the building fresh air intake, intakes of nearby buildings and noise to the occupants and local residential areas.
3. If a building is connected to the Central Cooling Water (CCW) system, provide a heat exchanger and secondary pumping system to decouple from the CCW utility.
4. Size the chiller(s) with sufficient capacity to accommodate estimated future loads. Incorporate capacity control strategies to limit short-cycling and provide efficient operation during present and future loading.
5. Provide redundant capacity for the process chilled water system where a shutdown is not tolerable.
6. As a general practice, do not provide mechanical cooling in general use buildings, except for libraries and large auditoria. Buildings may need ambient and/or process cooling. Provide ambient cooling to maintain the ventilation air temperature. Provide process cooling to meet equipment loads.

Design Criteria

1. Establish project design criteria for the following items:
 - a. Chiller type,
 - b. Chiller refrigerant type and quantity in pounds; refrigerant machinery room calculation; see Refrigeration section,
 - c. Cooling tower type,
 - d. Cooling tower air intake and discharge locations,
 - e. Cooling tower chemical treatment system,
 - f. Equipment location,
 - g. Reliability of the system, i.e. quantity of equipment for maintenance and repair work,
 - h. Humidity requirements,
 - i. Future system expansion provisions,
 - j. Special equipment cooling requirements, e.g. lasers,

- k. Chiller room alarm monitoring and ventilation,
 - l. Carbon footprint.
2. Provide equipment with weatherproof enclosures and screening if roof mounting is required.
 3. Size the chilled water distribution piping for the ultimate load based on 4 feet/second nominal velocity.
 4. Provide a supply air temperature of 60° F for buildings cooled by the CCW System.
 5. Calculate system differential pressure based on anticipated pressure drop for existing and future equipment. For process chilled water loops, base the system pressure on equipment differential not less than 30 psi. Locate the differential pressure controller two thirds of the distance to the most distant point of the system.
 6. Depending on the level of reliability required for the system, the following equipment may need to be on the emergency power for non-life safety systems. Coordinate with UW Project Manager.
 - a. Chilled water circulating pumps,
 - b. Chillers,
 - c. Tower fan and condenser water circulating pumps,
 - d. Controls.

All additions to the emergency power for non-life safety systems must be discussed with Engineering Services.

7. Locate water-cooled chillers in the basement mechanical room for the best vibration isolation situation.
8. Provide lead-lag pumps for both the chilled water and condenser water systems.
9. Use glycol to prevent freezing of condenser or chilled water coils exposed to freezing outside air.
10. Provide an expansion tank fitted with automatic fill and drain for the chilled water system.
11. Provide controls that prevent the chiller from operating unless chilled water pump, condenser water pump, condenser fan, etc. are operating.
12. Provide Flow/No-Flow switches to verify pump operation and use heat dissipation of the chilled water or condenser water to sense flow.
13. Provide access platforms as required for maintenance of rooftop-mounted cooling towers or chillers.
14. The central equipment for ambient cooling is located in the power plant and includes both steam absorption and electrical centrifugal chillers to meet the load.
15. Provide make-up water and blowdown/drain meters for cooling towers. See Meter Section for information.
16. Chemical treatment systems for cooling towers are preferred over non-chemical water treatment systems. Please discuss with Engineering Services if a non-chemical treatment system is being considered.
17. Provide secondary containment and an eyewash and safety shower for cooling tower chemical storage areas.

CCW-CPP Design Criteria

1. The CCW-CPP System operated as a primary pumping system with pressure differential manually controlled at the CPP. Additional controls located at the building control the building differential pressure.
2. The CCW-CPP System temperature and pressure varies during the operating season. Use the following for design conditions:

Season	Nominal Supply Temperature, °F (at CPP)	Nominal Return Temperature, °F (at CPP)
Summer (early-May through early-October)	42 °F	56 °F
Winter (early-October through early-May)	Unconditioned (typ ~60-70 °F)	Unconditioned (typ ~60-70 °F)

3. During the winter months, a nominal flow of water is maintained through the CCW-CPP System. Provide each building with a winter/summer control switch as noted in detail Central Cooling Water Building Header and Coil Connection.

CCW-WCUP Design Criteria

1. The CCW-WCUP system operates as a primary pumping system with pressure differential automatically controlled based on a sensor near ARCF/Hitchcock. Additional controls located at the building control the building differential pressure.
2. The CCW-WCUP System temperature and pressure varies during the operating season. Use the following for design conditions:

Season	Nominal Supply Temperature, °F (at CPP)	Nominal Return Temperature, °F (at CPP)
All Seasons	42 °F CCWS @ 70° F OAT reset linearly to 52 °F CCWS @ 40 °F OAT; waterside economizer below 48 °F OAT	Variable, 14 °F ΔT

CCW Header at Building

1. Locate the CCW header along a wall adjacent to the tunnel entrance at a convenient height for maintenance and repair access.
2. Each plant delivers central cooling water to interconnected distribution piping with manual isolation valves for separating the plant's service sections.
3. Delta P Valves are required at each cooling coil or heat exchanger to set flow limit to maintain high return differential temperatures to the chillers. No substitution allowed.
4. At each building CCW cooling coil or heat exchanger, provide a two way, pressure independent control valve, Delta P Valve as manufactured by Flow Control Industries, Inc., no substitutions.
5. A typical building header and coil connection is shown in the Central Cooling Water Building Header and Coil Connection detail at the end of this section. Provide the appurtenances such as bypass relief valves, pressure gauges, thermometers and isolation valves shown on this detail.
6. Pipe the bypass relief valves to relieve pressure from the building side of the isolation valve to the CPP side of the isolation valve. The valves relieve water when the differential across the relief valves exceeds 15 psig. Provide and fasten a metal nameplate to the valve to label the manufacturer, model and spring range. Cash Acme or Kunkel; no substitutions allowed.

Installation, Fabrication and Construction

1. Locate the chilled water loop for each floor in the corridor, easily accessible to all spaces. Locate isolation valves for each space in the most accessible area (either in the corridor ceiling space or inside the room.)
2. Provide isolation valves at all air vents.
3. Install expansion tanks with drain, air vent, and lockshield shut-off valve.
4. If two-way control valves are used, provide a 1-inch bypass line with globe valve for throttling at the most remote coil to allow continuous flow through the building piping.

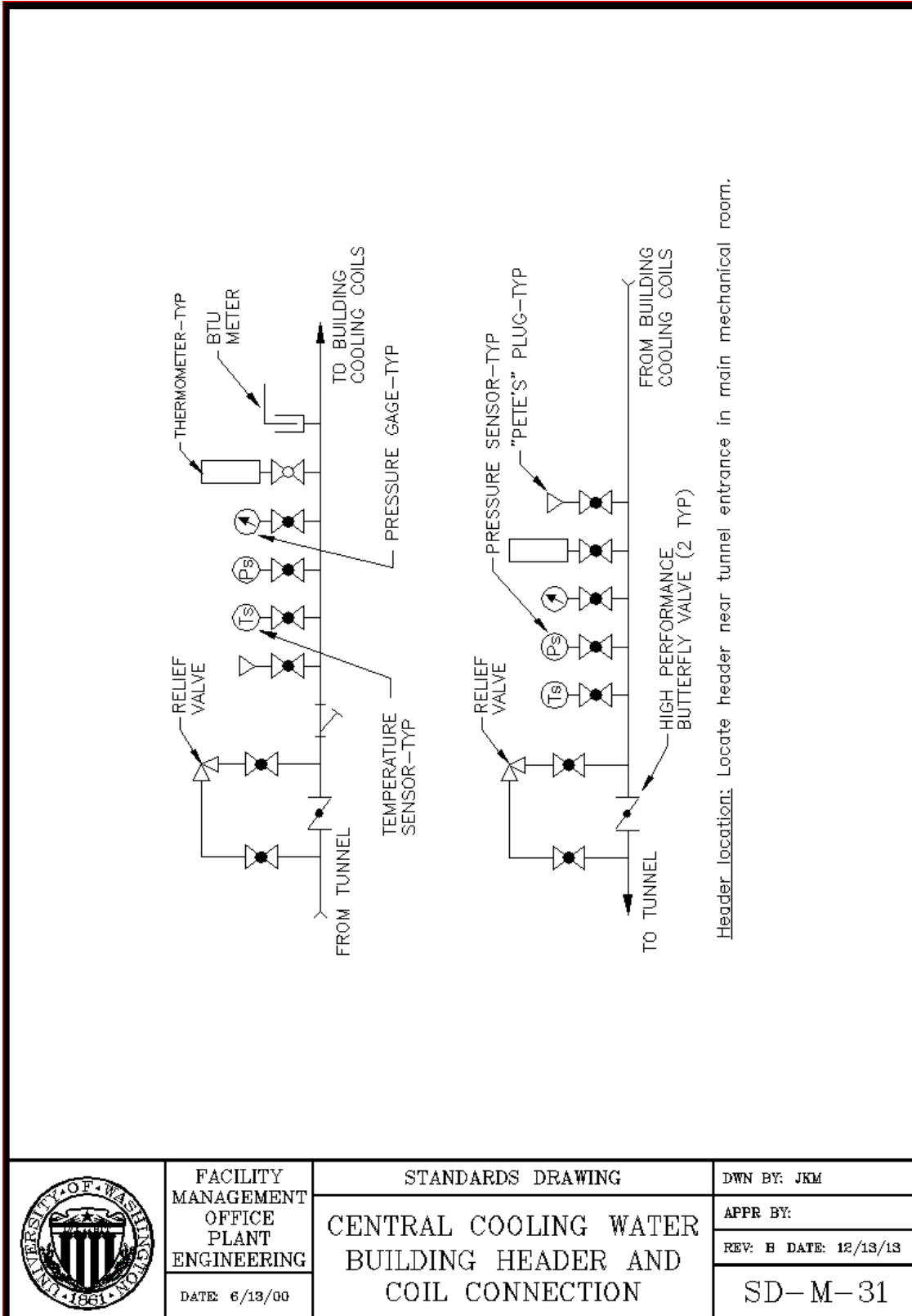

FACILITY
MANAGEMENT
OFFICE
PLANT
ENGINEERING
DATE: 6/13/00

STANDARDS DRAWING
CENTRAL COOLING WATER
BUILDING HEADER AND
COIL CONNECTION

DWN BY: JKM
APPR BY:
REV: B DATE: 12/13/13
SD-M-31

C. Building Steam and Condensate

Design Criteria

1. Heat all buildings with steam from the power plant whenever feasible. Steam is available at 185 psig and/or 10 psig. Use 10 psig steam whenever possible because it benefits the operation of the power plant turbine generator. The 185 psig steam is reserved for use in buildings distant from the power plant (i.e., Campus Parkway and South Campus) and laboratory buildings that need the higher pressure steam for laboratory or process use. Provide local building two-stage pressure reducing stations to reduce the 185 psig steam down to 15 psig for use on all building heating systems. To meet varying load conditions provide pressure reducing stations with parallel 1/3 and 2/3 full load valves per stage. Pressure reducing stations shall be complete in every detail to include gate valves for isolation, strainer, drip trap and strainer assembly, relief valves, and pressure gages. Steam radiant heating is not acceptable except for special applications approved by Engineering Services.
2. Convert Power Plant steam to hot water at all buildings to meet all heating requirements except one-way air (100% outside air) system preheat coils. Use steam in one-way air system preheat coils to prevent freeze damage to the system. Provide two-position control valves on preheat coils in one-way air systems. Use low pressure steam, no greater than 15 psig; size the preheat coil based on 7 psig steam to the valve.
3. See Metering section for steam/condensate meter and monitoring requirements.
4. Recommended AHU coil arrangement in order from the outside air intake to the supply fan on a draw thru system is (heat recovery, steam preheat, heating water, and cooling coil). Discuss with Engineering Services if different.

Products, Material and Equipment

1. Provide inverted bucket-type traps at the end of high pressure steam mains. Provide float and thermostatic type traps for low pressure steam mains.
2. Provide pneumatic rather than self-contained steam control valves on hot water converters.
3. Hand valves for radiators or convectors should be packed type suitable for servicing.
4. Converters must be ASME approved, stamped, and State Boiler Inspector's certificate forwarded to University. Use low pressure steam only (15 psig maximum) with capacity based on 7 psig steam to the control valve.
5. Provide slip-type pipe expansion joints. Bellows type pipe expansion joints are not acceptable.
6. Provide 1" warmup bypass pipe with globe valve across all main building steam isolation valves and all tunnel steam isolation valves.
7. Orient steam piping and install steam traps to avoid accumulating steam condensate above vertically oriented steam shutoff valves.
8. Where inverted bucket traps are used, avoid traps that lose their prime during low load conditions then need to be manually re-primed.
9. Preferably, avoid use of noise reduction orifice plates at steam PRVs.
10. See Steam Trap Assembly detail at the end of this section.

Installation, Fabrication, and Construction

1. Provide steam headers with valved branches to each specific load, hot water, storage heater, converter, heating coil, etc.
2. Provide pressure reducing stations with at least two valves sized for 1/3 - 2/3 of total load. Show loads on drawings.
3. Flash high pressure steam (185 psig) condensate in a flash tank to the low pressure steam system.
4. Drip and trap all low and medium pressure steam (1 - 110 psig) supply main branches over 12 feet long.
5. Provide strainers ahead of traps on coils, converters, or other heat exchangers. Provide adequate static head (minimum 12") above traps to insure proper operation.
6. Do not lift condensate by steam pressure.
7. Do not install steam or condensate piping below slabs on grade.
8. If steam is intended to be used for temporary heat, discuss with Engineering Services. For temporary heat, dump condensate to sanitary sewer by tempering to below 140°F.

D. Coils and Filters

Coils

1. Provide detail drawings of cooling coil drain pan traps. For AHUs, assure that condensate trap has sufficient depth to overcome fan static pressure and the height of the drip pan connection is sufficient for the trap to clear the floor.
2. Use condensate drain pan dimensions sufficient to catch all condensate off coil. Provide pan under coil and extend downstream of coil far enough to catch all condensate.

Filters

1. Provide MERV 8 pre-filters and MERV 13 final filters. Final filters shall have 85% efficiency (dust spot method using atmospheric dust)
2. Use 24 inch by 24 inch filters if possible.
3. Provide filters for specific applications (e.g. HEPA, grease).
4. Size filters at max. 500 feet per minute face velocity.

Products, Material and Equipment

1. Provide non-freeze type steam coils with perforated inner distribution tubes with vertical tubes; each section should be individually trapped. Tube wall thickness must be 0.035 inches (minimum).
2. For systems that require freeze protection, provide inhibited propylene glycol. Do not provide glycol feed system for closed loops.
3. At the high points in the water systems provide automatic air vents with a cast iron body, copper ball float and needle, or ball-type air valve. Provide manual air vents on zone heating coils. Provide low point drains on hydronic systems.
4. Provide a maximum fin density for coils of 10 fins per inch and tube wall thickness of 0.035 inches (minimum).
5. Locate and arrange air conditioning equipment for reasonable motor, filter, and coil/tube removal.

Installation, Fabrication and Construction

1. Provide a hose end drain valve on each water coil.
2. Locate all air heating and cooling coils so that water jet or steam cleaning may be employed on each side of each coil. Provide ductwork access panels on each side of each coil.
3. Provide a balancing valve in the return piping from each individual coil.
4. Provide isolation valves with rising stems or quarter turn valves at the inlet and outlet of each AHU or supply fan coil, or other major component. Locate valves so that each unit, and its control valve, can be serviced without draining an entire system or riser.
5. Provide access panels in ceilings or partitions for servicing concealed coils.
6. Provide a flow-measuring device such as a Venturi in the coil piping of each supply fan.

7. Indicate the required coil equipment access and removal space on the contract documents.

E. Computer Server Rooms

Basis of Design

In support of the UW's efforts to meet its climate goals and objectives, no new server rooms or upgrades are to be designed into new or existing buildings on any of the campuses of the University of Washington. A server room is defined as a separate or shared space used to store, power, and operate computer servers and their associated components in support of business functions. Business functions are all of the activities that support the work of the University, whether academic, administrative, research, or clinical in nature.

This policy is effective immediately and applies to all University campuses, schools, colleges, and departments, including those in partnership with the University through affiliations, and third-party entities operating in University facilities. Campuses, schools, colleges, and departments are henceforth directed to work with the UW Information Technology (UW-IT) unit on solutions for meeting technology requirements.

University policies, standards, guidelines, and procedures institute controls that are used to protect and operate University assets and resources efficiently and effectively. While every exception to a policy or standard weakens the overall efficiency goals and intent of the policy, occasional exceptions may be necessary. See UW Administrative Policy Statement 17.1 which defines the process for the review, approval, and time limit of exceptions to this policy statement.

If the exception is granted, please contact Engineering Services to obtain FDS section that outlines design criteria for computer server room design.

F. Refrigeration

Design Criteria

1. Provide design criteria and calculations for refrigeration system, including the following items:
 - a. Refrigerant type
 - b. Calculated refrigerant quantities of refrigerant machinery room, all rooms served by the refrigeration system, and all rooms with refrigerant piping routed through rooms.
 - c. Identify rooms with refrigerant that exceeds quantity threshold per code
 - d. Provide scheme for warning and exhaust systems to comply with code requirements
2. Design air-cooled condensing units using an ambient temperature of 95 ° F. Design to operate at a low ambient temperature of 0° F.
3. To improve efficiency and avoid short-cycling, incorporate a compressor capacity-control scheme; such as hot gas bypass or multiple compressors staging With the exception of refrigeration systems that incorporate heat recovery.
4. Allow sufficient ventilation for air cooled condensing unit heat rejection. Do not install units in an enclosed space.
5. Regulate condensing unit fan speed to control the condensing system operating pressure. For multiple fan units, regulate the fans on a "first on last off" basis.
6. Provide compressors located remotely from evaporators with oil separators. Design oil circulation piping to ensure adequate oil circulation.
7. Install refrigeration compressors, condensers, and condensing units in a mechanical room or in a weather-protected enclosure.
8. Provide evaporator condensation drains with a trap and route to funnel or floor drains. Provide condensate pan and piping with insulation.
9. Implement the "pump down" method to control compressors. Provide compressor controls with a low-pressure switch, primary control and a high-pressure limit with manual reset. Provide compressors designed with pressurized oil lubrication which have an oil pressure safety switch with timer and manual reset.
10. Provide a minimum of 400 cfm per ton for evaporator units.
11. Fluorocarbon refrigerant R-22 is not acceptable. Eliminate all CFCs from existing facilities. Provide EPA approved HFC refrigerant for new equipment (if not available, discuss with Engineering Services). CFC and HCFC are not acceptable.
12. Size Variable Refrigerant Flow (VRF) systems small enough to avoid classifying non-communicating spaces as refrigerant machinery rooms.
13. Where a refrigerant machinery room is required, design as follows:
 - a. Refrigerant leak detection system must be per [Preferred Vendors](#) list.
 - b. Locate refrigerant leak detection panel inside the Refrigerant Machinery Room, with at least one remote panel connected to that system located outside the main entrance to the Refrigerant Machinery Room. If remote panel is located in an accessible common area, install

- panel in lockable cabinet. Consult with Engineering Services for key number to be used on lockable cabinet.
- c. Refrigerant leak detection system must be compatible with the Fire Alarm System and the Building Automation System.
- i. The Fire Alarm System monitors status of the Leak Detection System for alarm and trouble (including loss of power) conditions.
 - ii. During normal operation, the Leak Detection System commands the ventilation system to normal occupied airflow rate.
 - iii. Upon an alarm signal at the Leak Detection System, the Leak Detection System commands the ventilation system to the emergency airflow rate. Transmit an alarm signal to Fire Alarm Panel and the Building Automation System. The audible and visual alarms are activated
 - iv. The Fire Alarm System and the Building Automation System monitor normal speed fan(s) status via current sensing relays. During failure of fan(s) to operate at normal speed in normal mode, generate a supervisory signal at both the Fire Alarm System and the Building Automation System. Fans shall default to the emergency airflow rate. The audible and visual alarms are activated.
 - v. The Fire Alarm System and Building Automation System monitor emergency speed fan(s) status via current sensing relays. During failure of fan(s) to operate at emergency airflow rate in emergency mode, generate a supervisory signal at the Fire Alarm System. The audible and visual alarms are activated.
 - vi. The Fire Alarm System monitor leak detection panel status via trouble contact. During failure of leak detection panel, generate a trouble signal at the Fire Alarm System. Upon panel failure, fan(s) default to emergency airflow rate. The audible and visual alarms remain inactivated.
- d. Legally required standby power must be supplied from UW Emergency Power System.
- e. Leak detection system alarm level must be set to the refrigerant's Permissible Exposure Limit (PEL). Where calibration gas is not available at the PEL, set the alarm level for the lower calibration gas level. For example, adjust the set point to 900-ppm when the PEL is 1000-ppm, if 1000-ppm calibration gas is not available.
- f. Locate refrigerant audible and visual alarm devices outside each refrigerant machinery room door and within the refrigerant machinery room as per ASHRAE 15/34 and NFPA 72. Audible alarm devices to have a continuous tone. Visual alarm devices to have blue acrylic light covers.
- g. Provide all refrigerant audible and visual devices with signs permanently hung below the device(s). Signs must be three-layer etched plastic with white letters on a blue background. Letters must be a minimum of 1/2" high.

Signs within the refrigerant machinery room must read:

WHEN FLASHING

REFRIGERANT LEAK / NO FAN

EXIT SPACE

Signs outside each refrigerant machinery room entrance must read:

WHEN FLASHING

REFRIGERANT LEAK / NO FAN

DO NOT ENTER SPACE

- h. Refrigerant machinery room systems must be commissioned, with a written functional test procedure reviewed by Engineering Services developed to ensure the system is calibrated and tested per design. The functional test will be witnessed by Engineering Services and Fire Alarm Shop.

Products, Material and Equipment

1. Provide maximum warranty option for compressors.

Installation, Fabrication and Construction

1. Braze all pipe joints under a nitrogen purge. No mechanical couplings allowed. No Flare connections.
2. All work must be performed by a contractor with a valid City of Seattle Refrigeration Mechanics license. A & B Refrigeration Handlers Certificate with a Universal Rating are also required where applicable.
3. Subject completed systems to the field test as stipulated in the latest edition of the Seattle Mechanical Code. The University's Representative must witness this test.
4. Complete Refrigeration Compliance Forms. The University can provide these forms or download from <https://www.washington.edu/facilities/fstech/node/609>.

G. Ductwork and Duct Pressure Testing

Design Criteria

1. Select duct velocities to meet N.C. requirements of each occupied space. NC level requirements to be identified in the Basis of Design narrative. Coordinate required NC levels with University Project Manager and users.

Supply, Return and Non Fume Exhaust Ductwork

1. Provide a 6-inch pressure rating for supply ductwork and plenums between the supply fan and the zone terminal boxes; for ductwork downstream of the terminal box, provide a 2-inch pressure rating.
2. Use the ASHRAE Handbook of Fundamentals chapter on duct design to determine the allowable leakage rate (cfm/100 sq. ft.) at the specified test pressure for each type of ductwork on the project other than fume exhaust ductwork. Specify for each type of ductwork the duct pressure rating, the pressure to apply during the duct leakage test, and the allowable cfm/100 sq. ft. leakage rate at the test pressure.
3. Minimize use of square elbows. Provide turning vanes in square elbows of supply ductwork. Do not use turning vanes in return or exhaust ductwork.
4. Do not use perforated plate ceiling diffusers in office or classroom applications. They cause drafts.
5. Specify laminar flow diffusers in laboratory applications when required.
6. Do not use nonmetal ductwork (i.e. fiberboard, fabric) without the approval of Engineering Services.
7. Design ductwork to and from the HVAC equipment so that stratified air is mixed properly before entering branch ducts or downstream equipment.
8. Limit flexible duct to no more than 6 feet and one elbow.
9. On renovation and remodel projects, provide a preliminary air balancing report with current and design airflows.
10. On renovation and remodel projects investigate the condition of existing duct liner, in particular at cooling coils. Test for mold and replace duct liner if warranted.

Dampers

1. To minimize noise, install manually operated, opposed blade or single blade, quadrant-type volume dampers on all branch main and branch duct takeoffs from the main duct to control the amount of air entering or leaving the branch. Locate those balancing dampers adjacent to the connection to the main branch.
2. Indicate balancing damper location for each outlet and each inlet.
3. Avoid register or diffuser-mounted dampers because they cannot reduce large volumes of air without causing objectionable air noise levels.
4. To minimize generated duct noise, locate volume dampers at least two duct diameters from a fitting and as far away as possible from the outlet or inlet.

5. Provide the necessary access space around components to allow the TAB technician to take proper readings. Allow adequate straight duct sections from fan outlets, elbows, or open duct ends to provide accurate duct traverse readings.

Pressure Relief Doors or Panels

1. Smoke/fire dampers have the potential to damage ductwork if they close by accident, or even if they close when the fan is shut off but wheeling down during a power outage, fire test, or fire. Risk of damage to the ductwork is particularly serious if a single smoke/fire damper can stop the full supply of air into or out of a large fan. Design the air distribution system so that the ducts won't be damaged if the fans are run with the smoke fire dampers closed.
2. The preferred means for protecting the ductwork against over-pressurization during smoke/fire damper closure is to select a duct pressure classification so the ducts can withstand sudden exposure to the maximum fan pressure. Provide accessible, well-sealed pressure relief doors or panels that can be closed after they open.
3. Use pressure relief doors rather than pressure relief backdraft dampers.

Mounting

1. For roof-mounted ductwork, fans and air handlers, see the architectural standard drawing titled Mechanical Equipment Mounting for minimum mounting height.

Renovation and Expansion Projects

1. When adding or removing ductwork on an existing air distribution system, show on the mechanical drawings all existing ductwork and flow rates required to be rebalanced after construction.
2. Review manufacturer's fan data for existing fans to ensure these fans can operate at the new operating conditions. Review existing motor amperage and motor nameplate to determine if a new fan motor is required.
3. In the fan schedules, provide the existing and proposed fan airflows, fan static pressures, motor amperages and motor horsepower requirements for existing fans serving systems altered in renovation projects. The existing actual flows are needed for the design. Arrange with the University of Washington Project Manager for flow measurements as needed.
4. On floor plans, show any new balancing dampers required in the existing branch ductwork to facilitate balancing.
5. Require measurements, prior to demolition, of any unknown airflows or static pressures required to be reestablished as part of testing, adjusting and balancing.
6. If a small portion of an existing system is to be changed, avoid creating a new high pressure drop critical path to an existing system. Select larger components to avoid significant increases in the fan discharge pressure requirements.
7. Provide temporary means as necessary for dust control and lab safety while ductwork and fans are being removed and installed.

Fan-powered Zone Air Terminal Boxes

1. For VAV air terminal box fans, specify the method of speed adjustment (e.g., continuous or 3-speed fan control) to be used during testing, adjusting and balancing. In reviewing manufacturer's literature during design and during contractor equipment submittals, make sure the selected air terminal boxes operate at a speed range that doesn't create excess noise or motor problems. Specify "extra-quiet" fan-powered VAV boxes.
2. Specify maximum sound ratings (db. level) for the air terminal boxes.
3. To control sound transmission out of the secondary (plenum) air intake, include a lined intake boot that has at least one 90 degree elbow.
4. On mechanical floor plans, indicate with dotted lines the horizontal access clearance requirements for maintenance of air terminal boxes.
5. Connect fan powered air terminal boxes to the ductwork with flex connections.
6. Connect fan powered air terminal boxes to structure with vibration isolators unless the fans are internally isolated.

Smoke/Fire Dampers

1. The smoke/fire dampers and their actuators are to be covered under the ductwork specialties section of the project specifications (not under controls or the fire alarm system). Exception: The EP switch for smoke/fire damper pneumatic actuators is specified under the fire alarm system. Coordinate with electrical and refer to Environmental Health & Safety Design Guide – Fire Alarm System section.
2. The University strongly discourages use of engineered smoke control systems. Consult EH&S before designing one.
3. Work with the Architect and EH&S to minimize the number of smoke/fire dampers through (1) coordination of duct layout with suite configuration, and (2) close attention to code "exceptions" to standard smoke/fire damper placement requirements.
4. Pneumatic actuators are preferred. If electric smoke/fire dampers are used, discuss actuator application including noise with Engineering Services.
5. Dampers to be Class II, 250° F, with a minimum closure time of 7 seconds and a maximum closure time of 15 seconds.
6. Fire damper actuating device to be rated at approximately 50° F above normal operating temperature within duct system. Rate for 286° F for smoke control systems.
7. All smoke/fire dampers must be self-resetting.
8. Provide end switch for position verification.

Access Doors and Panels

1. Coordinate with Architect to ensure there are access doors through walls and hard ceilings wherever necessary to reach access doors in the HVAC equipment.
2. Provide a minimum of 24" x 24" size access doors and panels unless the duct is too small to accommodate a larger door or the necessary access can be handled easily with a smaller door.
3. Coordinate with Architect so that all access doors and panels in the ductwork are accessible in a manner that meets applicable safety standards. This includes access doors and panels located at the smoke/fire dampers.

Hospitals, Labs, and Animal Holding Facilities Pressure Relationships

1. On hospital, lab, and animal holding facilities projects, discuss with EH&S and Engineering Services whether there are any special requirements for documentation and review of room pressure relationships.
2. See EH&S Laboratory Safety Design Guide.

Construction Submittals

1. For smoke/fire damper submittals: Include the number of damper actuators in each damper bank, and an equipment list showing the manufacturer, model number, and amperage draw for the actuators in each damper bank (whether composed of a single or multiple dampers).
2. Include manufacturer's literature on the smoke/fire damper actuators.
3. For projects with electric smoke/fire dampers, provide shop drawings that show electrical and mechanical coordination of smoke/fire dampers.

Products, Material and Equipment

Accessories

1. Provide insulated drip pans for cooling coils.
2. Damper position switches that contain mercury are not acceptable. Use cam action, lever, or proximity type damper position switches.

Ductwork – Non Fume Exhaust

1. Provide an easily accessible lockable, handle for each balancing damper. Orient the handle parallel to the damper blade(s).
2. Use aluminum sheet metal with watertight joints for exhaust ductwork from high humidity areas such as shower rooms. Slope ductwork back toward inlet.

Fan-powered Zone Air Terminal Boxes

1. Internally isolate the fans in air terminal boxes.
2. Line the air terminal boxes with at least 1 inch of fiberglass batt insulation. Cover liner with aluminum foil at least 0.001 inch thick to prevent entrainment of fibers into the air stream.
3. Damper shafts to have at least one flat facet at the point of connection to the actuator.

Damper Shafts

1. Provide a grooved scribe running parallel to the blades on the end of each damper shaft to indicate damper position.

Fume Exhaust Ductwork

1. See EH&S Laboratory Safety Design Guide.

Buried Fiberglass Reinforced Plastic (FRP) Ductwork

1. Submit design and calculations for buried FRP for review and approval.

2. Construct FRP per industry standards and manufacturer's recommendations.
3. Buried RFP thickness to withstand bearing loads from soil and structure above, in addition to any applicable ductwork suction pressure.
4. Provide counter weight and properly strap down buried FRP to resist buoyant force.
5. Compact soil to an unyielding state. Provide minimum 6" thick pea gravel underlayment and compact to an unyielding state prior to installing the FRP.
6. Ensure installing system free from unnecessary stresses.
7. Slope ductwork and provide drainage as needed.

Smoke/Fire Damper Actuators

1. Provide pneumatic actuators for the smoke/fire dampers unless the building doesn't have other pneumatic controls. (The Facilities Services Design Standard requires pneumatic actuators for HVAC controls in mechanical rooms. See the Environmental Control Systems section.)
2. Serve pneumatic actuators for smoke/fire dampers with pneumatic lines made out of hard drawn copper tubing that meets copper tubing specifications under Environmental Control Systems.
3. Electric actuators to have an end-switch or clutch to reduce force on the damper when it is being held open. Do not use stall-motors on electric actuators.

Access Doors

1. Access doors to be hinged, latched, and gasketed. Where located in insulated ductwork, provide an access door that is double walled and insulated to same level as duct in which they are located.
2. Access panels need to open and close easily without damage to duct insulation, and reseal tightly on re-closure.

Installation, Fabrication and Construction

General

1. Expose no raw fiberglass fibers to the air distribution system air stream or to occupied space.
2. During storage, transport, and installation prior to start-up, cover the ductwork and air terminal boxes with plywood and/or plastic as necessary to keep them dry, clean, and protected from damage.
 - a. Replace metal that is dented or has a damaged finish.
 - b. Replace duct liner that is torn or wet.

Ductwork

1. Specify to cover the ends of ductwork while they are in storage and after installation prior to start-up, so they are protected from accumulation of dirt.
2. Thoroughly clean ductwork and plenums of debris and small particles of rubbish and dust before installing and making final duct connections.

3. Locate plenums at least 4 inches AFF to protect them from water in case of mechanical room flooding. Provide adequate support.
4. Provide each plenum area with a light. Include an "ON" pilot light on switch.

Fume Hood Ductwork

1. Slope all horizontal ductwork down towards the fume hood. Low points or "bellies" in the ductwork run are unacceptable.
2. Some retrofits may require to tie-into existing glazed ceramic ducts and vitrified clay tile ducts. Provide appropriate transition detail.
3. Decontaminate fume hood ducts being removed as part of the project.
4. Provide a flanged removable spool piece (minimum of 12 inches long) at each fume hood connection. Use spool sections for leak tests, inspection, and to facilitate removal of equipment. Install suitable gaskets at flanged joint connections.
5. Provide adequate space and easy access to facilitate inspection, repair, or replacement of exhaust ducts.
6. The target design velocity in each duct is in the range of 1200 to 1500 feet per minute (fpm) to prevent condensed fumes or particulates from adhering to the walls of the ducts, settling out onto horizontal surfaces, and to address acoustical issues. The actuated exhaust terminal unit needs to consider noise and prevention of product deposition in the ducts.

Fume Hood Exhaust Stacks

1. See Environmental Health & Safety Laboratory Safety Design Guide for air flow study requirement.
2. Terminate fume hood exhaust stacks at whichever is the greatest of the following: At least ten feet above the roof for workers safety or stack height as determined by the air flow study.
3. Design discharge stack velocity to be at least 3000 fpm.
4. Do not provide exhaust stacks with weather caps or louvers, which require the air to change direction or cause turbulence upon discharge. Provide means to drain rainwater from exhaust stacks.

Zone Fan-Powered Air Terminal Boxes

1. Cover air inlet and discharge openings for air terminal boxes while they are in storage and after installation, prior to start-up to prevent accumulation of dirt.
2. Coordinate location of filters for easy access and replacement.
3. Orient secondary air inlets either down or sideways, not toward the ceiling.
4. Provide enough clearance between the secondary air inlet and the nearest surfaces to avoid restriction of air flow.

Access Doors

1. Provide hinged access doors on rectangular ductwork, air handlers and plenums. On round and oval ductwork provide removable access panels.

2. Provide access doors for all plenum areas. Provide latches operable from both inside and outside the plenum.
3. Provide access doors that open against pressure, and are self-closing due to the direction of airflow and by pressure differential. No exceptions.
4. Provide access panels upstream of all fire dampers, smoke/fire dampers, and coils, and elsewhere where occasional access is required. Provide access panels to both sides of turning vanes.

Duct Pressure Tests

1. Pressure test all ductwork in shafts, all plenums, fume exhaust ductwork, snorkel exhaust ductwork and all ductwork with a pressure rating of more than 2 inches (negative or positive). For ductwork with a pressure rating of 2 inches or less (negative or positive), test two Owner selected supply ducts on each floor, and one Owner selected exhaust or return duct
2. Demonstrate to an Owner representative that the ductwork passes the following pressure tests before it is insulated or covered by walls or ceilings. Test ductwork after all associated smoke/fire dampers, fire dampers, pressure relief doors, and access doors have been installed.
3. Discuss test pressures applied to each system with Engineering Services.
4. Before testing, provide the Owner- with the table or curve of pressure drop versus flow for the orifice being used to measure leakage. Provide data that is certified and an orifice that is clearly labeled so that a correlation between the orifice and table can be established.
5. Maintain a set of drawings for recording and sign-off of each tested section.
6. After each day of testing, submit to the Owner a copy of the paperwork recording the raw test data, calculating the duct areas, designating the duct category, and comparing the allowable and actual results.
7. Maintain pressure testing records on site. Provide a copy of current pressure test results if requested by an Owner Representative.

General Environmental Supply, Return, Exhaust, and Outside Air Ductwork Test Procedure

1. Close off and seal openings in the duct section to be tested. Connect the test apparatus to the duct by means of a section of flexible duct.
2. Test for leaks as follows:
 - a. Start blower with its control damper closed.
 - b. Gradually open the control damper until the duct pressure reaches 2 inches W.G. in excess of designed duct-operating pressure.
 - c. Survey joints and seams for leaks. Mark each leak and repair after shutting down blower. Do not apply a retest until sealants have set.
 - d. After leaks have been sealed, retest failed sections of ductwork until satisfactory results are obtained. Contact the Construction Coordinator to schedule an Owner's Representative to witness re-tests.

Fume Exhaust Ductwork Test Procedure

1. Connect a blower to the duct specimen through a shutoff valve. Provide a magnehelic gage or inclined manometer with 0 inches to 10 inches W.G. range on the duct side of the shutoff valve.
2. Provide temporary seals at all open ends of the ductwork.
3. Average test pressure shall be 6 inches w.g. Initial pressure shall be 7 inches w.g.
4. Test all fume duct joints from the fume hood collar to the fan inlet flex connection, not inclusive.
5. To prevent over-pressurizing the ducts, start the blower with the variable inlet damper closed. Controlling pressure carefully, pressurize the duct section to the required level. When the pressure of the duct reaches 7 inches W.G., close the shutoff valve.
6. Using a stopwatch, measure the time elapsed from when the duct is at 7 inches w.g. to 5 inches w.g. Use the formula $t = 6.23D$ to determine if the duct passes the test. ("D" is the nominal duct diameter, measured in inches; "t" is the MINIMUM allowable elapsed time, measured in seconds.)

Pressure Relief Doors or Panels

1. Demonstrate to an Owner's representative that the relief devices are functioning per the design intent and the ductwork is not damaged during a fire alarm test.

Smoke/Fire Damper Tests

1. As part of the test, the Contractor needs to demonstrate to an Owner's representative the full functionality of each smoke/fire damper by visual observation of the blades as it strokes "full open" and "full closed." All of the smoke/fire dampers need to pass the Owner-witnessed test before tests are witnessed by the Fire Department. To allow observation of the damper blades, Contractor to open access doors before the test begins.

Fire Damper Tests

1. The Contractor to demonstrate to an Owner's witness that the fire dampers drop from the "full open" to the "full closed" position by gravity when the fusible link is removed. Perform tests for the Fire Department only after fire dampers have passed the Owner-witnessed test before tests are witnessed by the Fire Department. Open access doors to allow observation of the damper blades by the Contractor before the test begins.

H. Hydronic Heating

Programming

1. Establish laboratory and research space temperatures as part of the technical programming process. Design unoccupied spaces, including mechanical and electrical rooms, to be heated to a minimum of 40° F for freeze protection.

Design Criteria

1. Programming for new hot water converters to include a reset schedule. Confirm existing reset schedule. Reset converter and radiation water temperatures by the outside air temperature. The normal reset schedule for a converter is to reset the water temperature from 180° F to 140° F as the outside air temperature changes from 20° F to 70° F respectively. The normal reset schedule for a radiation system is to reset the water temperature from 180° F to 100° F as the outside air temperature changes from 20° F to 70° F respectively.
2. Provide hot water heating radiation systems in areas where people are located adjacent to the outside wall. Examples of this type of occupancy are perimeter office areas and study carrels in libraries. Radiation systems are not required in lab areas, auditoria, or other areas where people are not seated along the exterior wall. Size radiation systems for 80% of transmission losses. Select finned pipe radiation to extend for the entire length of each glass area. If the perimeter heat loss does not exceed 250 BTUH/LF, radiation may be omitted.
3. Provide separate pumps and decoupled distribution systems for radiation systems and reheat coils. Discuss with Engineering Services if the systems are too small to justify separate systems. Stand-by pumps are required for critical systems. Please discuss standby requirements with Engineering Services and the Project Manager.
4. Reheat coil hot water is normally set at 140° F.
5. Night setback temperature control is required to protect the building and the equipment inside. Buildings with wood floors or equipment that would be affected by humidity (wood expands) are not allowed to drop below 55° F. Temperatures below 55° F have caused wood floors to buckle and pianos to go out of tune. For some buildings, a night setback temperature of 40° F, for freeze protection only, is acceptable. Discuss with Engineering Services and the Project Manager.
6. For up-feed system install control and isolation valves next to the apparatus on the same level.
7. Provide pipe test ports/wells to measure pressures and temperatures at each piece of equipment.
8. Provide a pot feeder, coupon rack and make-up water meter on each hydronic heating systems.

Products, Material and Equipment

1. For heating water piping, see Piping, Accessories and Pipe Pressure Testing section.
2. For systems that require freeze protection, provide propylene glycol.
3. Provide a 0.001 waterside fouling factor for the hot water converter selection.

4. At the high points in the water systems provide automatic air vents with a cast iron body, copper ball float and needle, or ball-type air valve. Provide manual air vents on zone heating coils. Provide automatic air vents on pre-heat heating coils. Provide low point drains on hydronic systems.
5. Surface mounted convectors must have sloping top to prevent materials from being placed/stored on top of the enclosure and blocking airflow. Avoid custom enclosures.

Installation, Fabrication and Construction

1. Provide sectionalized down-fed hot water piping systems with isolating and drain valves to simplify servicing without draining large volumes of water during maintenance and repair.
2. Allow space for tube removal on each hot water converter.
3. Provide relief valves on each hot water converter in compliance with the Boiler and Pressure Vessel code.
4. Do not install cast iron radiation, finned radiation, and air heating coils on the same pumped circuit.
5. Provide a hose end drain valve on each hot water coil.
6. Provide isolation valves at all air vents.
7. Locate expansion tanks at the highest point possible, and fit with gauge glass, drain, vent, and shut-off valve.
8. Provide control valves on convectors and radiation; dampers are not acceptable.
9. Provide isolation valves with rising stems at the inlet and outlet of each AHU or supply fan coil, or other major component. Locate valves so that each unit, and its control valve, can be serviced without draining an entire system or riser.

I. Ventilation Design Criteria

This section provides the design criteria for air handling units, ventilation fans and ductwork.

Design Criteria

1. When feasible, specify fan speeds less than 1,000 rpm to reduce noise levels and increase equipment life.
2. Fan installation in penthouses or mechanical rooms is preferred. Provide weatherproof protection for outdoor fans.
3. Locate the fan as the last element of the exhaust system to assure that the ductwork throughout the building is under negative pressure.
4. Install fans to be readily accessible for maintenance and inspection without entering the plenum. If exhaust fans are located inside a penthouse, consider the ventilation needs of maintenance workers.
5. Discuss laboratory ventilation interlocks and standby power requirements with EH&S and Engineering Services.
6. Coordinate the mechanical design with fume hood selection and location to achieve design performance criteria listed in the EH&S Laboratory Safety Design Guide.
7. Ventilate mechanical and electrical rooms for temperature control. The temperature setpoint to be a maximum of 90° F unless there are specific equipment temperature requirements. Provide outside air to all mechanical and electrical rooms as part of the ventilation system.
8. Provide provisions for future ventilation for ductwork and piping systems for storage rooms that may eventually become offices. Storage rooms are not considered unoccupied areas.
9. To maintain optimal indoor air quality, locate air intakes to avoid contamination from streets, exhaust vents, loading docks, and other sources of contamination. Locate outside air intakes a minimum of ten feet above grade. For air intake requirements see EH&S Laboratory Safety Design Guide.
10. To protect the air intake locate all building exhausts as remotely as possible from the intake. All fume exhaust systems must be located on the roof and discharge vertically.
11. Provide rain hood with bird screen for air intake. Avoid air intakes on southern elevations to minimize wind-driven rain and snow entrainment. Avoid using moisture eliminator in lieu of rain hood as it has high pressure loss and water collected on the louver is frequently drawn into the system before reaching the drainage gutter. For airflow simulation study requirements see EH&S Laboratory Safety Design Guide.
12. Most building systems require large units, in the 20,000 to 75,000 CFM range. The use of multiple small package units is discouraged.
13. Separate ventilation systems or zones may be required for separate occupancy uses, such as libraries and auditoria. The occupancy schedule of these areas are not always the same. Make provisions to run these areas when the remainder of the building is not in operation.
14. Do not use operable doors or windows as part of a pressurization or smoke control system where it may compromise building security.

15. Provide building copy/duplicating rooms and other rooms that contain several personal computer printers with exhaust systems to eliminate the migration of dust and chemicals. To maintain adequate indoor air quality, do not recirculate the air from these rooms.
16. Do not use fan rooms and mechanical rooms as supply or relief/exhaust air plenums. Duct all outside air and relief/exhaust air ducts to outdoors.
17. For fume exhaust, see Ductwork and Duct Accessories section and EH&S Laboratory Guide Manual.
18. Minimize return air plenums. Provide ducted return air system. Discuss with Engineering Services if plenum returns are proposed.
19. For separate snorkel exhaust system requirements see EH&S Laboratory Safety Design Guide.
20. Obtain current airflow and hydronic reports for remodel projects or system retrofits, as the actual operating conditions are likely different from the original design data.
21. Provide blow through design roof mounted supply air systems to eliminate negative pressure plenums exposed to the weather.
22. For naturally ventilated spaces specify the space temperatures to be maintained and provide supporting calculations.
23. Where designs incorporate fan arrays, provide a fan array airflow measurement system to measure individual fan airflow rates and total air handling unit airflow rate as well as fan alarming.
24. Select duct velocities to meet N.C. requirements of each occupied space. Identify NC level requirements in the Basis of Design narrative. Coordinate required NC levels with University Project Manager and users. Limit duct velocities to 1200 fpm for general supply and exhaust. Design fume hood exhaust duct velocities between 1200 and 1500 fpm.
25. See EH&S Laboratory Safety Design Guide for the following systems:
 - a. laboratory ventilation interlocks and standby power
 - b. air intake
 - c. airflow simulation study
 - d. fume exhaust
 - e. snorkel exhaust

Plumbing

J. Compressed Air, Vacuum, Natural Gas & Nitrogen

Design Criteria

1. See Campus Mechanical Systems Section for connection to campus compressed air system.
2. Provide minimum 30 psig compressed air to laboratories. Provide separate service for systems with different pressure requirements.
3. The dew point of the utility compressed air service is in the range of 40°F. Consider using an air dryer at service entrance to meet system dew point requirements.
4. If required, provide a separate valved branch to serve each of the environmental control air system and the fire protection system at the building service entrance.
5. Provide central building laboratory vacuum systems with an ASME receiver where practical. Duplex liquid ring pumps are the preferred type. Provide a liquid trap upstream of the receiver.
6. Vacuum pumps to be controlled by a pressure switch in the receiver set to operate between 22 and 25 inches of mercury vacuum.
7. Provide isolation valves at each floor and for each laboratory and equipment connection.
8. Size compressed air, vacuum and nitrogen pipes based on equipment specified demand or 0.5 scfm per outlet if none specified. Apply reasonable diversity factors based on user's input.

Installation, Fabrication and Construction

1. Pitch vacuum pipes in the direction of air flow.
2. Connect vacuum branch to the top of the main
3. Natural gas or natural gas vent piping must never be installed in the campus utility tunnel system.
4. Natural gas service entrance piping must be protected from accidental damage by vehicles, foundation settlement, or vibration. Where practical, the natural gas service entrance pipe to
5. Be above grade and provided with a self-tightening swing joint prior to entering the building.
6. Natural gas meters must be installed outside the building to avoid leakage concerns.
7. Immediately prior to turnover to the Owner, contractor must ensure that odor is present at natural gas lab outlets and odor fade has not occurred.

K. Potable and Nonpotable Water

Design Criteria

1. When incoming water pressure exceeds 80 psig, provide a pressure reducing station with two parallel PRVs (each sized at 2/3 of total flow, each valved to operate independently.)
 - a. Design the system to provide a minimum pressure at the highest point of the building as needed for connected systems or at 25 psig, whichever is greater.
 - b. The assembly to include appropriate valves, strainers, gauges, drains, etc. and include a bypass.
2. Provide the laboratory non-potable water system with parallel RP devices each sized 2/3 of the laboratory supply pipe capacity to prevent need for shutdown to test and repair. Protect the laboratory water system by installing faucets with built-in and un-removable vacuum breakers.
3. Locate irrigation system backflow preventers inside the building mechanical room.
4. Divide water system into smaller systems and provide isolation valve for each floor, each laboratory, each restroom and each plumbing fixture.
5. Design plumbing systems for sports stadiums, classrooms and auditoriums to handle load spikes.
6. Design piping with flow velocity not to exceed 4 feet per second.
7. Provide booster heaters for dishwashers and other equipment requiring hot water temperatures higher than building system design.
8. Do not install water piping below slabs on grade except for trap priming lines. Protect copper pipes from contact with concrete.
9. Provide electronic sensor faucets for all lavatories. Do not use electronic sensor flushometers for toilets and urinals.
10. For emergency safety shower and eyewash stations, refer to EH&S Laboratory Safety Guide.
11. Waterless urinals not allowed. Provide a full size domestic water by-pass around rainwater harvesting systems with adequate capacity to support all connected loads.
12. Provide a full-size domestic water valved by-pass around water pressure booster pumps.
13. Where a flood prevention valve is installed, provide a full-size valved bypass around flood prevention valve, or redundant flood prevention valves on building water supply.
14. Piston type flush valve for urinal and water closet using reclaimed water is not acceptable.
15. **See UW Standard Drawings:**

Water Filter Header

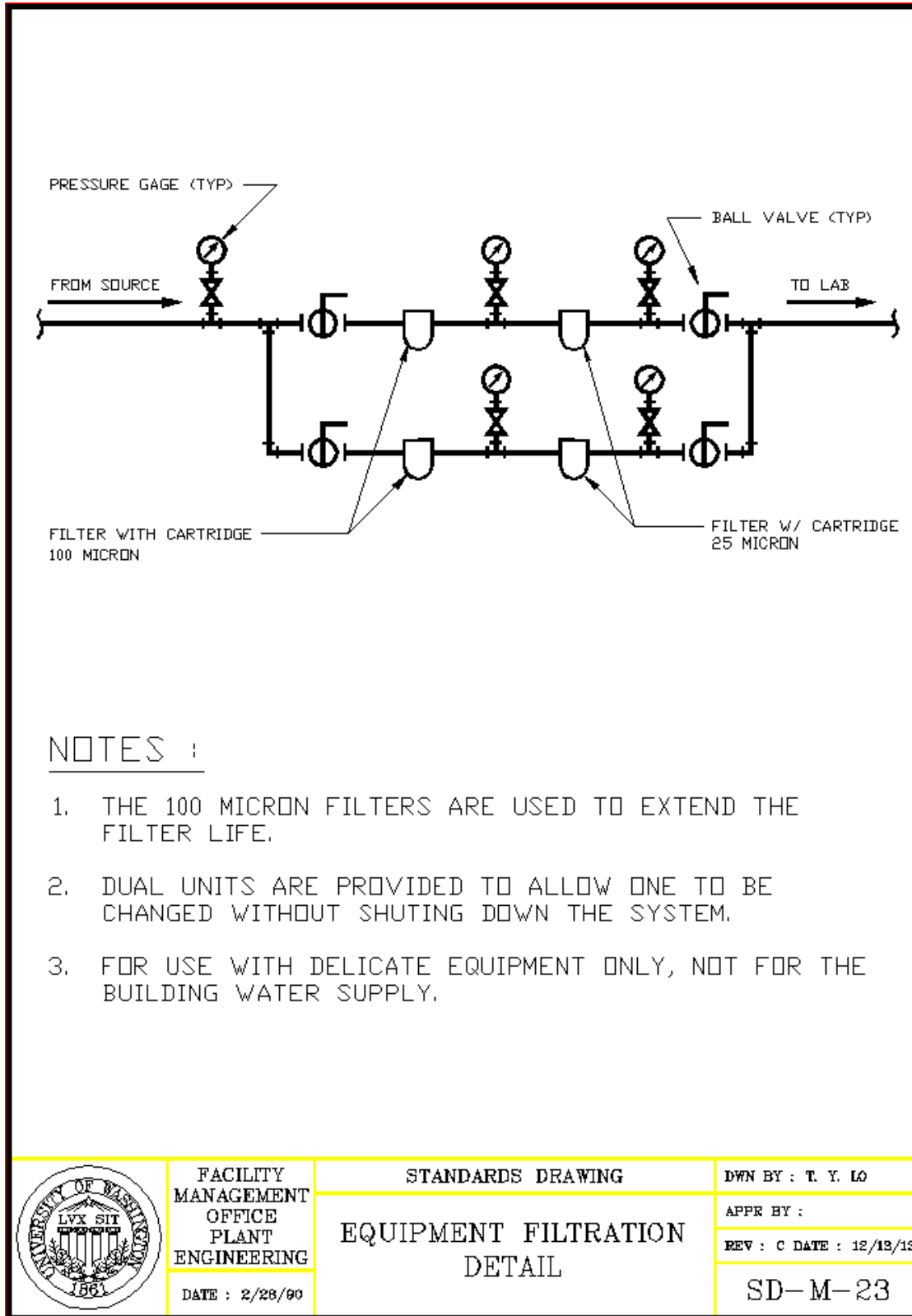

NOTES :

1. THE 100 MICRON FILTERS ARE USED TO EXTEND THE FILTER LIFE.
2. DUAL UNITS ARE PROVIDED TO ALLOW ONE TO BE CHANGED WITHOUT SHUTTING DOWN THE SYSTEM.
3. FOR USE WITH DELICATE EQUIPMENT ONLY, NOT FOR THE BUILDING WATER SUPPLY.



FACILITY
MANAGEMENT
OFFICE
PLANT
ENGINEERING
DATE : 2/28/00

STANDARDS DRAWING
EQUIPMENT FILTRATION
DETAIL

DWN BY : T. Y. LO
APPR BY :
REV : C DATE : 12/13/13
SD-M-23

Typical Building Water Header

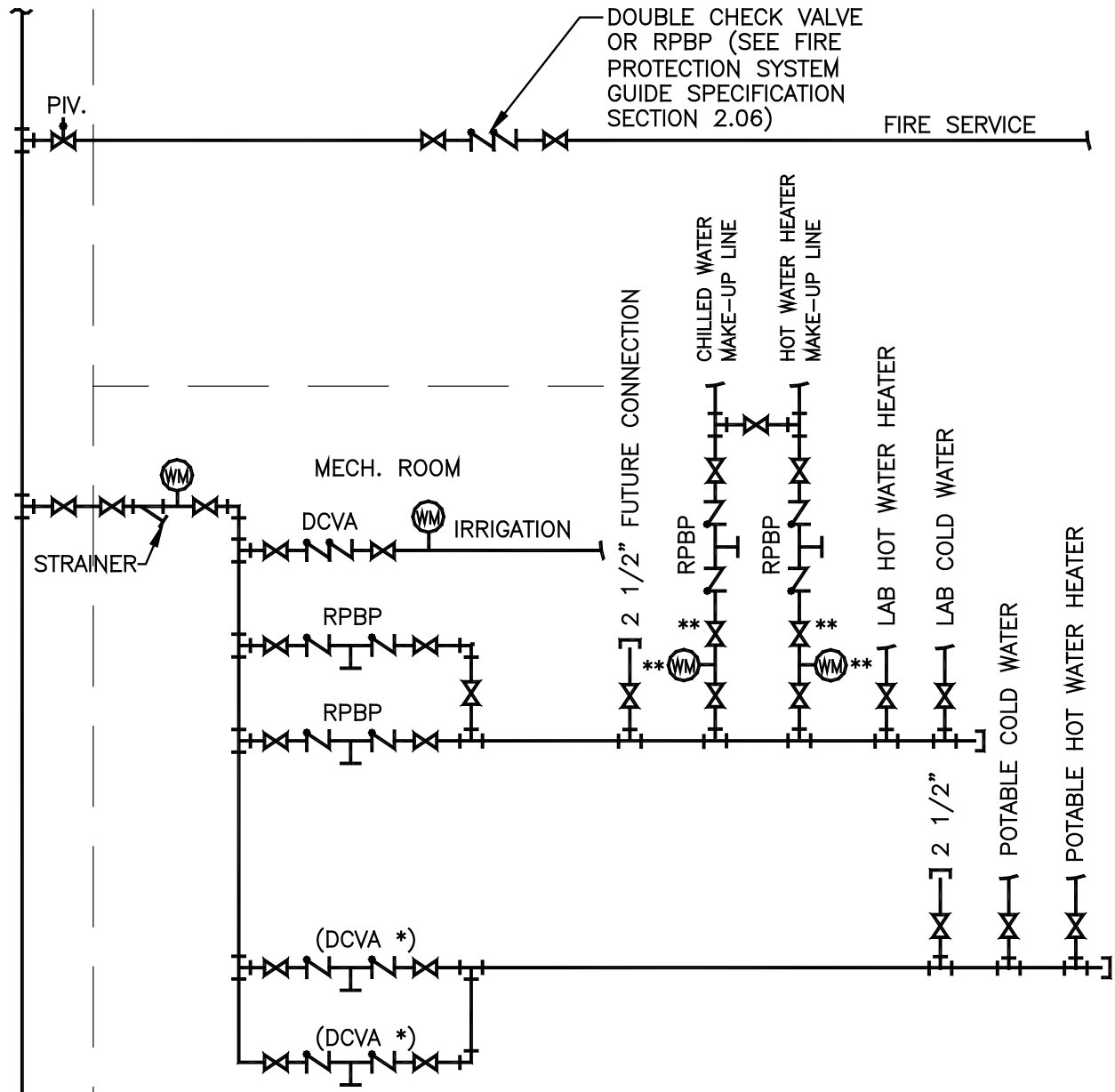

LEGEND

- * RPBP REQUIRED ONLY ON BUILDING WITH HAZARDOUS PROCESSES.
- DCVA REQUIRED FOR ANY BUILDING OVER 30' HIGH
- RPBP REDUCED PRESSURE BACKFLOW PREVENTER
- DCVA DOUBLE CHECK VALVE ASSEMBLY.
- ** REQUIRED ONLY FOR SYSTEMS WITH GLYCOL CONCENTRATION.

SD-M-19

L. RO/DI

Design Criteria

1. The minimum water purity standard for RO/DI systems is the College of American Pathologists (CAP) Type II. Provide Point-of-Use polishing equipment, if higher purity is required
2. Typical central equipment to consist of flushable prefilters, multi-media filters, reverse osmosis unit(s), deionizers, carbon filters, ultraviolet lights, storage tank, and distribution loop pumps.
3. A water heater may be required upstream of the RO unit because they are most efficient when operated at an inlet water temperatures of 77°F.
4. Design system to circulate RO/DI water continuously in a closed series loop layout from the central equipment to lab outlets throughout the building. The distribution loop piping must be sized to circulate the water at a velocity in the range of 4 to 6 feet per second under no demand conditions.
5. Provide RO/DI system storage tank capacity for 24 hours of estimated usage. Coordinate with the structural engineer for storage tank support.
6. Provide access for storage tank sanitization.
7. Install storage tank overflow pipe with a check valve or p-trap equipped with trap primer supplying suitable water quality.
8. Discuss point of use equipment.
9. Discuss water reclaim from RO/DI reject water.

Installation, Fabrication and Construction

1. Slope all horizontal piping to allow for free draining with a minimum slope of 1/8 inch per foot.
2. Minimize dead end pipe sections in the distribution system. Provide branch pipe drop to each outlet or piece of equipment. Dead ends to be no more than six pipe diameters.
3. Provide diaphragm valve for each pipe termination.

M. Waste and Drains

Design Criteria

1. Provide minimum 6-inches diameter side sewers.
2. Provide gravity waste drains. No waste pumping allowed without Engineering Services approval.
3. Investigate alternate side sewer designs to explore feasibility of eliminating backwater valve where required by code.
4. Connect all footing drains to the storm drainage system. If connection to the storm drainage system is not practical, the footing drain may be connected to the tunnel drainage system. Do not connect footing drains to an interior sump pump.
5. Connect drains from vaults with oil-filled transformers and shop areas where oil is present to an oil interceptor.
6. Connect garbage disposal waste piping to a major waste pipe with as few bends as possible. Provide accessible clean-outs in the waste pipe.
7. Locate centralized grease interceptors outside in an area accessible by service vehicle.
8. Provide a 6-inch diameter drain with 36-inch high standpipe for the discharge of fire sprinkler system test.
9. Do not connect flammable or hazardous chemical/liquid storage room floor drains to the sewer systems. Design an alternate drainage system in coordination with the Fire Code or contain in place if allowed.
10. Due to the unstable nature of the soils East of Montlake Boulevard NE, it is recommended that all piping below slab on grade be hung from the slab rather than supported by the soil. Coordinate with the structural engineer for piping support from slab.
11. Coordinate cleanout locations with Architectural layouts.
12. When required, provide backwater valve of same material as sewer pipe.

Installation, Fabrication and Construction

1. Do not install crosses into waste piping systems.
2. Connect to top of pipe and use a 1/8 bend located for branch connections to food service area waste piping.
3. Support waste and drainage piping crossing excavated areas on pre-cast concrete beams. Support concrete beams by the building structure and undisturbed earth.
4. Specify full size clean-outs for up to 4 inches. Use 4-inch clean-outs for all piping larger than 4 inches.
5. Floor drains: Slope floors to floor drains. Specify block-outs twice the size of the drain body and infill with non-shrink grout to prevent perimeter cracking at concrete.

N. Water Reclaim System

To meet the water conservation initiative of the University, all major projects are encouraged to install a water reclaim system.

Water Reclaim and Rainwater Harvesting

1. Consider potential sources for water reclaim:
 - a. Rainwater (Do not harvest rainwater from green roof)
 - b. Rejection from RO/DI water
 - c. Cooling coil condensate recovery

Cistern

1. Do not harvest rainwater from green roof
2. Slope to low point
3. Overflow to storm system
4. Valving is required if the location is a permit required confined space

Piping and Pumping

1. Provide bypass around water reclaim system to ensure a continuous water supply

Filtration and Water Treatment

1. Use UV for water sanitization in lieu of chemical treatment if feasible
2. Calcite filter for pH

Reclaimed Water Usage

1. Ensure water quality is suitable for any specific use
2. Consider use of reclaimed water for the following:
 - a. Toilets/Urinals
 - b. Irrigation
 - c. Cooling Tower

Specific Mechanical Systems

O. Commissioning

Background

1. New facilities have become much more complex, requiring that new methods of start-up and operation be employed to assure that each facility functions as intended.
2. There are many critical participants involved with a comprehensive building commissioning program. The participants are the Commissioning Agent, Contractors, Consultants, and the Owner. The Commissioning Agent is engaged directly by the Owner, and the Test Engineer is a member of the prime Contractor's team. The commissioning agent and the test engineer have clearly defined responsibilities, and both become the essence of the final quality assurance program.

Design Criteria

1. Consultant to provide Owner's Project Requirements (OPR) document with input from Owner.
2. Depending on a project size and scope, the UW will typically hire a Commissioning Agent directly. This is a firm skilled in commissioning facilities of the type represented by the specific project and is referred to as the Commissioning Agent or Authority. The Commissioning Agent is hired prior to construction to be available to work with the Design Team and Contractor. In some cases the Commissioning Agent may be hired during design to contribute expert advice before the project is bid. Commissioning of the project's life safety systems need to be coordinated with and approved by UW Environmental Health and Safety.
3. The specific duties of the Commissioning Agent are:
 - a. Review the Contractor's systems start-up plans.
 - b. Review the Contractor's equipment and component test procedures.
 - c. Review the Contractor's systems and inter-systems functional performance test procedures.
 - d. Witness, verify and approve satisfactory completion of equipment and component tests and systems and inter-systems functional performance tests.
 - e. Review and approve specified documentation.
 - f. Coordinate the TAB firm's participation in the project.
 - g. When commissioning has been successfully completed, recommend final acceptance to the Owner.
 - h. Provide a project commissioning plan and functional performance test (FPT) procedures to be reviewed and approved by the project team.
 - i. Generate and maintain an issue log throughout the commissioning process
 - j. Provide the final commissioning report in a timely manner
4. Generally, the contract documents require the prime Contractor to engage a Test Engineer to organize, schedule, and conduct all equipment and apparatus tests and prepare and perform all system functional performance tests. This organizing, scheduling and testing is presented to the Commissioning Agent and UW Environmental Health and Safety for fire/life safety projects for review and approval.

5. The primary roles of the Test Engineer are to develop appropriate test procedures for all equipment/systems being tested, complying with the manufacturer's standards and procedures, and to ensure that all is successfully completed within the contract completion period.
6. The specific duties of the Test Engineer are as follows:
 - a. Develop schedules for all testing; integrate testing into the master construction activity schedule; and coordinate all subcontractor testing.
 - b. Perform system tests during both the winter and summer modes. Temperature tests can only be made on a design day. The Commissioning Agent is responsible to return to the site on a design day to complete these tests.
 - c. Coordinate directly with each subcontractor on the project specific to their responsibilities and contractual obligations.
 - d. Observe the start-up and initial testing of equipment by the Contractor and subcontractors, and then all final tests of equipment and systems.
 - e. Manage all cross system testing such as HVAC, building automation, fire alarm, emergency power, life safety, elevators, etc.
 - f. Review operation and maintenance information and as-built drawings provided by the various subcontractors and vendors for verification, organization, and distribution.
7. The Commissioning Agent may be hired prior to construction to be available to work with the Design Team and Contractor (Please consult with Engineering Services at early design phases). The Commissioning Agent can contribute expert advice before the project is bid.
8. For projects with a MACC less than \$3 million, it may not be necessary to require the prime Contractor to engage a Test Engineer. The scope of commissioning and the extent of commissioning requirements may be reduced as may be appropriate to the complexity and sophistication of the specific project. These decisions must be made by the Consultant and the University, via specific discussion of the commissioning program, and all related decisions and commitments made prior to the end of the design development phase.
9. Even though a Test Engineer may not be required on all projects, commissioning requirements for the project are still incorporated into the contract documents. The prime Contractor is required to designate, in writing, a member of the construction team to be responsible for the commissioning program.
10. For all projects, a critical requirement for the prime and subcontractors is development of the comprehensive test procedures for equipment and systems. This test is based on the operating criteria, test parameters, and acceptable results required. Many contractors have not had experience in this area. Therefore, someone who specializes (or has had experience) in development of test procedures is required.
11. The University has developed a library of test procedures for the range of equipment and systems it has commissioned. To a degree, there is a somewhat generic quality regarding test procedures for common equipment and systems. However, in every instance, such procedures must be carefully reviewed and adapted to the unique characteristics and design conditions of the project.
12. The University makes this material available to consultants and contractors for reference during design and construction. Doing so helps to reduce the time required for such development,

develop more consistent testing/commissioning, and gradually improve the quality of the program.

Construction Submittals

1. Preliminary submittal
 - a. Commissioning plan
 - b. Basis of Design documentation
 - c. Sample installation audit forms
 - d. Draft startup plan
 - e. Draft commissioning schedule
 - f. Draft functional performance test procedures
2. Final submittal
 - a. Commissioning plan
 - b. Basis of Design documentation
 - c. Installation audit forms
 - d. Startup plan and startup forms
 - e. Functional performance tests
 - f. Commissioning progress reports
 - g. Commissioning issues matrix
 - h. Commissioning meeting minutes
 - i. O&M preliminary review
 - j. Owner Training Plan
 - k. Final Commissioning Report

P. Environmental Control Systems

Environmental Control Systems Overview

Provide a standalone building management system for operating the mechanical system and interfacing with the campus FACNET

Approved Manufacturers (no substitutions):

1. Siemens Industry Building Technologies Issaquah Branch
2. Johnson Controls Bothell Branch
3. Alerton by ATS Automation

Hardware and Software

1. Operator Stations - Local Operator Station (LOS) Provide a PC station in a designated operations room with all required hardware and software. All components to be the latest version, capacity and speed available in the current high-end consumer market.
 - a. Microsoft windows base operating system
 - b. A complete software package with optimal architecture with pulldown menu and "one-click" approach
 - c. A video and audio card capable for dual monitor displays
 - d. Ports for connections with all peripheral components and network interface. Provide a minimum of two spare for each type of ports
 - e. Power surge protection
2. Laptop - Portable Operator Station (POS): Provide on laptop with the same general functions and features as the LOS
3. Controllers - Each controller to be stand-alone control upon communications failure. The controller to retain its programming during a power failure and resume operation without program reloading from another device.

Graphic Display

1. Submit all graphic screens for approval prior to implementation. Display all controlled and monitored equipment within the graphics screens.
2. Display systems on a single graphic.
3. Provide floor plans with the approximate location of equipment, sensors and monitored points.
4. Provide a summary page including setpoints, real time values, and valve and damper positions for each air handling unit system.
5. Provide sub-graphic for each major system including sequence of operation and setpoint values.
6. Provide dynamic graphics for fans, pumps, compressors, dampers that show a different color when operating (green). Indicate when a component is alarm with flashing red.

Interface

1. FacNet - The contractor shall provide all hardware, software, and licensing to provide secure communication, over the campus FACNET using TCP/IP, from the LOS or POS within the facility to the vendor's campus server for their system
2. Secured DDC Room – Provide a dedicated, ventilated, well-lit and secure control room to house the environmental control system's main terminal, operating manuals, and mechanical drawings.
3. Connection Port Enclosure – Install the campus Ethernet connection port inside a 12x12x6 inch lockable enclosure.

Interfacing the DDC with Equipment Built-In Controls

1. Indicate the relationship between the environmental control system and the dedicated (built-in) controls for specific HVAC equipment such as chillers, heat pumps, furnaces, and boilers.
2. Use built-in controls provided under other sections of the project specifications to handle staging and coordination of parts within each major piece of equipment. This provides a sole source of responsibility for the equipment's performance to avoid damage to the equipment, to increase safety, and to increase Contractor and manufacturer responsiveness during problem solving
3. The building's environmental control system may offer monitoring and enable the local controls for "on/off." Review with Engineering Services which parameters to be monitored by the environmental control system.
4. Operation of multiple supply terminal boxes in a single zone presents special problems. Discuss with Engineering Services.
5. Ensure adequate power and transformer sizing for devices starting and operating simultaneously (e.g. window actuators, damper actuators, blind operators, etc.)

Interfacing the DDC with Fire Alarm

1. Control system to return to normal operation unattended in stages after a power outage or fire alarm.
2. The fire alarm system must control life safety mechanical equipment such as those serving shaft pressurization systems, refrigerant machinery rooms, or smoke control systems. At fans shut down by the fire alarm system, shut down authority to be effective for all positions of the local HOA or VFD controls. The environmental control system does not control fans after shutdown by the fire alarm system until after reset of the fire alarm system and reset of fire/smoke dampers. Toilet and other non-recirculating exhaust fans to remain on unless this creates a problem of excessive pressure on exit doors. Fume hood fans to remain operating. Consult with EH&S for further information.
3. Specify provision for a current switch for fire alarm system "run status."

Interfacing the DDC with Emergency Power

1. In buildings where mechanical systems operate under DDC control in emergency power conditions, the environmental control system to monitor the fire alarm panel to determine when

the building is under a fire alarm condition. The Environmental Control System to monitor the appropriate emergency power transfer switch to determine when there is loss of normal power and restoration of normal power.

2. Specify a restart schedule indicating equipment start-up priority.

Standby Power

1. Provide standby power for all FacNet Switches and control panels.
2. Provide a UPS (Un-interruptible Power Supply) having 5 year battery life and battery hot swappable capability for all cabinets containing controllers. Provide with fused duplex receptacle as the UPS power source. Monitor the UPS and provide an alarm point.

Renovation and remodel projects

1. Contact Engineering Services to decide what type of space and front-end equipment for the control shop will need to operate the system.
2. Pneumatic to DDC - The goal is to move from pneumatic to DDC controls. Consultant to evaluate this goal against limitations in project budget and schedule. Work with Engineering Services on a project-by-project basis to determine how these goals are to be balanced on a given project.

Sensors

1. Provide a tamperproof enclosure.
2. Hard-wire fan high-limit pressure switches and low-limit freeze stats
3. Provide a test port at each piping sensor.

Deliverables

1. Training - Specify provision for a minimum of 32 hours of classroom and on-site training in the operation and maintenance of the installed system. For the first training session, hold eight hours of this training prior to point to point testing.
2. SetPoint List - Provide a list of all the design setpoints and the final setpoints after commissioning is complete.

Q. Identification

Products, Material and Equipment

Control Wiring

1. Heat shrink labeling

Piping

1. Asbestos-free labeling: White lettering on a blue background label to read "asbestos free". All other piping labels to have black lettering on a white background unless regulated; the color of the labeling is regulated by safety codes.
2. For loop piping systems, indicate on the labels whether they are supply or return pipes.
3. For cooling water pipes connected to the campus tunnel system, state "Central Cooling Water" on the labels. For chilled water pipes connected to a chiller within the building, state "Chilled Water" or "Process Chilled Water" on the labels.
4. Indicate pressures on labels for steam lines with pressure greater than 20 psig and on all gas lines (such as nitrogen, compressed air, etc.) over 30 psig.

Plumbing Fixtures

1. Labels for non-potable fixtures to have black ½-inch lettering and yellow background on either self-adhesive waterproof paper, plastic, or vinyl.
2. Labels for potable fixtures to have white ½-inch lettering and sky blue background on either self-adhesive waterproof paper, plastic, or vinyl.

Valves

1. On each valve tag, indicate the size and service.
2. Provide bronze valve tags that are 1" x 2½" with lettering 1/4" minimum height. Stamp or engrave tags lettering.

Equipment

1. Give the equipment name and I.D. on each equipment label. Use the identifiers given in the contract drawings.
2. Provide laminated black plastic equipment labels with lettering cut through to white background.

Installation, Fabrication and Construction

Piping

1. Throughout the project, indicate direction of flow and service at least once in each space, at least once every 20 feet, and at all wall penetrations for all piping.

2. Attach piping labels at each end with adhesive arrow bands around the full circumference of the pipe and overlapping at the ends.
3. Orient adhesive labels parallel to the pipe, and locate labels where they can be read from the floor or the most likely approach for access.
4. On all piping, apply labels stating “asbestos free” at least once in each space, at least once every 20 feet, and within 6 inches of each point of connection with existing piping insulation. Mark the circumference of the new insulation with a black marking pen at each point of connection with existing insulation and draw an arrow from the nearest “asbestos free” to the black line. On the arrow, write with the black marker “terminates here.”

Plumbing Fixtures

1. Non-potable: Identify all fixtures dispensing non-potable water per Seattle Plumbing Code.

Valves

1. Tag each valve.

Equipment

1. Provide an equipment label for each major piece of equipment. Air terminal box identification to be readable from the floor.

R. Metering and Gauges

Meter Installation

1. Install and commission main meters and submeters as specified in UW Purchase Specifications. Ask UW Facilities for a copy of the current Purchase Specifications, or visit <https://facilities.uw.edu/planning/design-standard>.
2. Provide all materials and cabling for a complete installation of each meter. Install meters per manufacturer's instructions. Test each metering system to meet data connection or transmission requirements.
3. Coordinate with UW Facilities to involve them in all meter discussions during planning, design and construction. UW Power Plant Meter Shop to provide steam condensate meter wiring connection diagrams for each project. Contractor to provide wiring diagrams for other meters for review and approval.
4. Coordinate the quantity and location of Facility Network (Facnet) Ethernet ports with Campus Utilities & Operations and UWIT. Contractor to provide a completed "Mechanical Meter Profile Report" form for each meter (see form below).

Gauge Installation

1. Provide thermometers and "pete's plugs" at all locations where fluid mixing or heat transfer occurs.
2. Provide pressure gages at all services entering the building, at pressure-reducing valve outlets, pump inlets and outlets, and on other equipment where required for confirming satisfactory operation.

Pipe and Fittings

1. Install thermometers where they can be read from the floor.
2. Mount pressure gages on ½-inch size pipe extensions with ½-inch shut off valves.

Pipe Accessories

1. Provide industrial quality thermometers with thermowell and 9-inch scale length. Provide a scale range of 30° to 240° F in hot water piping, or 0° to 100° F in central cooling water or chilled water piping.
2. Provide pressure gages with a 4-inch minimum size and a scale range approximately twice the operating pressure. Show units of measure on the face plate.

Duct Accessories

1. In fume exhaust ductwork, install two Pete's Plugs made of non-corrosive material in the exhaust duct at 90° to each other around the circumference for the purpose of pitot tube insertion.

2. Provide dedicated adjustable inclined manometer or magnahelic gauge on each air filter installed to indicate filter pressure drop.

Mechanical Meter Profile Report

Model:	
ID Number:	
Name:	
NVRAM:	

Firmware Versions

FirmWare	Boot	Runtime	Xilinx
Comm			
DSP			

Communication Settings

Item	Port 1	Optical	Port 4
Address			
Baud Rate			
Data Bits			
Parity			
Stop Bits 1			
Tx Delay			
Protocol			
Mode			

Time Setup

Time Zone:	
DST Enabled:	
DST Start:	
DST End:	

Line Sync:	
Frequency:	

Demand Setup

Block Window Sync

Thermal Averaging Window:		Use Sync Pulse:	
Block Averaging Window:		High Speed Input #:	
Rolling Averaging Sub-Interval Window:		Generate End of Interval Pulse:	
Rolling Sub-Intervals:		Relay #:	
Predictive Rolling Window Average:		Pulse Width (ms):	

Trending Log 1 Interval

Hours	Minutes	Seconds

Trending Log 2 Interval

Hours	Minutes	Seconds

Network Settings

IP Address	
Subnet Mask	
Default Gateway	
Gateway Port Baud Rate	
Gateway Port Delay	
MAC Address (IEEE Registered)	

DNS Servers

DNS Server 1	
DNS Server 2	

Services

Modbus TCP Server	
Modbus TCP Client	
BACnet IP Server	
BACnet IP Client	
Web Server	
SMTP Server	
SMTP Client	
FTP Server	
FTP Client	
HTTP/Modbus RTU Server	

Alarm/Email

Email Server IP Address/Name	
Email Server Port	
Email Monitor Address	
Return/Reply Address	
Email Subject Text	
Email Server Requires Authentication	
Username	
Password	

FTP Client

FTP Server IP Address/Name	
FTP Server Port	
Startup Remote Directory	
Username	
Password	

Network Card Firmware Update Via Network

Enabled	
Server Port	
Server IP Address	
Client IP Address	
Subnet Mask	
Default Gateway	
Download Filename	

DNP LAN/WAN Settings

Mode:	
-------	--

Connection:

DNP over TCP:		Listen on Port:			
DNP over UDP:		Listen on Port:			
Respond to:					

A	
---	--

S. Motors and VFDs

Electric Motors

1. Provide “off the shelf” motors that are readily available.
2. Provide NEMA rated 1800 RPM motors with Class F or H insulation when appropriately matched to the driven equipment. Do not select motor speeds requiring V-belt drive reduction ratios greater than 6 to 1.
3. Identify the type of control for every motor within the scope of the project.
4. Provide factory lubricated bearings for motors less than 1/3 HP. Sleeve bearings are only permitted for fractional HP motors and where specifically recommended by the equipment manufacturer as the better type of bearing for the application.
5. Provide vertical shaft motors with suitable thrust bearings.
6. Shaded pole-type motors \geq 1/8 HP are not acceptable.
7. Provide open drip-proof construction motors. Where conditions dictate provide enclosed or explosion proof type motors. .
8. Size motors to operate between 70% and 95% of full motor load when running at full 60 Hz speed. If a larger future load is anticipated, size the motor mounting pad to accommodate the larger anticipated motor frame size.
9. Provide shaft grounding ring for motors that are controlled by VFDs. Ensure grounding path from vibration isolated equipment.

Variable Frequency Drives

1. By-Pass Starter or Dual VFD: A manual by-pass starter or dual VFD is typically required when there is no redundancy. Discuss the use of a By-pass starter or dual VFD with Engineering Services. Critical-need applications without redundancy require an automatic bypass feature or dual VFD feature. In some critical applications, a backup fan or pump and VFD is provided, in which case by-pass starters or dual VFDs may not be necessary. Provide the by-pass feature or dual VFD to be fully isolated. Operate all safeties in by-pass or dual VFD mode. Operate VFD or bypass starter by Manual Start Operation. Require a soft start for motor 50 hp and greater.
2. Amperage interrupt capacity: Requirements can vary depending on the electrical system design. The nominal requirement is a 65,000 RMS symmetrical ampere interrupting capacity. Some electric services require less capacity, coordinate the mechanical with the electrical designer and comply with the protective device study to determine the appropriate specification.
3. Radio frequency sensitive applications: A VFD may be installed in the vicinity of highly sensitive research or medical equipment. Radio microphones and sound reinforcement equipment may also be susceptible to RF generated by a VFD. An appropriate FCC rating may be necessary in these applications, and this requirement may result in the use of 6-step or 12-step technology VFDs. Review with Engineering Services if control and interface requirements in the guide specification cannot be met.
4. Interface with Environmental Control System: The guide specification requires both hardwire and digital connection to the environmental control system.

5. Interface with the Fire/Life safety Systems: Ensure the Fire/Life Safety system operation sequence is met in Manual, Off, Auto, and Bypass Modes. Verify the correct speed is maintained in all Modes.
6. Sheaves and impellers: Use Motor Speed as the adjustment mechanism for balancing critical paths in air and water systems. After testing and balancing is complete, adjust sheaves, impellers and motor sizes as necessary so that the motor operates above 55 Hz and between 70% and 95% of full load amperage when the maximum desired system pressures and flows are produced. When the motor operates in VFD bypass at 60 Hz, verify that system pressures and flows do not cause problems and the motor current does not exceed full load amperage. It may be necessary to install pressure protection switches and/or duct blowout panels to protect variable air volume systems from over-pressure. Coordinate these requirements with the Testing and Balancing requirements.
7. Line reactance: Provide a minimum of 3% input line reactance. This may be provided in the form of separate line reactors at the input of the VFD, reactors included as part of the DC bus or a combination of the two totaling 3% to 5%.
8. Total Harmonic Distortion (THD): Specify in the documents that the THD at the point of common coupling for all VFDs connected, is less than 5% and to provide required filtering equipment in conjunction with line reactors.
9. Output rate of rise, peak output voltage and wire length: Purchase and install VFDs that does not damage typical premium efficiency motors. Implementing the following three requirements essentially eliminates motor insulation and bearing failures associated with VFD use.
 - a. Use output filtering to keep the rate of rise, for each pulse in the output, below 1,000 volts/microsecond.
 - b. Use output circuitry, which prevents the peak output voltage from reaching 1,000 volts to ground at the motor.
 - c. Limit wire length to less than 50 feet between the motor and VFD. Demonstrate the 50 foot distance in the contract documents.
10. Provide damper control accessory.
11. Provide display and keypad for all drives, mounted either locally through enclosure door or remotely.

Installation, Fabrication and Construction

Electric Motors

1. Do not expose motors to the weather. Install motors within the building or in suitable enclosures. If motors are not housed within the building structure, specify totally enclosed type motors, even though a weatherproof enclosure is provided. Provide motor heaters in outdoor enclosures.

Variable Frequency Drives

2. Mount the VFD as close to the motor as feasible with no more than 50 feet separation. Coordinate with the electrical designer to ensure that this requirement is met. It is also necessary that the VFD be solidly mounted to structural members.

- a. Unistrut type structures can be used in most mounting circumstances.
- b. Do not mount VFDs directly to the flexible sides of air handling units, plenums or ductwork.

Avoid mounting VFDs outdoors, inside plenums, or adjacent to piping that could spray a leak onto the VFD housing. Discuss VFD location with Engineering Services

T. Noise and Vibration Control

Design Criteria

1. Specify NC level requirement for each type of occupied space in the Basis of Design. NC levels to be approved by Engineering Services based on user's input.
2. Many campus buildings have vibration-sensitive equipment such as electron microscopes. Establish acceptable vibration criteria early in the technical program so that equipment, piping, and ductwork that require vibration isolation can be identified. Provide a table in the design documents which lists the vibration isolation requirements for piping, equipment and ductwork.
3. Analyze mechanical system equipment sound levels to control noise transmission. Select all mechanical equipment to meet the noise criteria (NC) requirement of each occupied space. Identify NC level requirements in Contract Documents.
 - a. Minimize the use of fiberglass liner inside ventilation ducts. Do not install liner between the supply fan cooling coil and the terminal unit. Do not install liner on outside air intake ductwork. Minimize liner in the return air duct.
 - b. Reduce fan and air noise by the use of sound attenuators, round or oval ducts, where feasible, instead of rectangular; Design fans at low RPM.
 - c. High density duct liner with foil face can be considered downstream of the terminal unit to mitigate cross-talk noise between rooms.
 - d. Insulate fan powered boxes with fiberglass and a hard, cleanable surface exposed to the air stream.
 - e. In renovation projects, existing HVAC systems with fiberglass liner in good condition may be left in place.
4. At University of Washington Medical Center projects, ductwork sound lining is not acceptable.
5. Provide acoustic treatment in mechanical room walls and ceilings if adjacent areas are affected by noises generated in the mechanical room. Coordinate interior finishes with Architect.
6. Avoid "Floating Slabs" i.e., slabs that are acoustically isolated from the structural slab with insulation between the two slabs. These slabs are usually constructed before the building is "closed in" or protected from rain. Consequentially they are exposed to rain which saturates the insulation, making the acoustical performance ineffective and providing a breeding place for mold and mildew.

Products, Material and Equipment

Vibration Control

1. Provide spring-type or rubber-in-shear vibration isolators for rotating equipment on grade.
2. Provide spring-type vibration isolators and inertia bases for rotating equipment in areas not on grade.
3. Provide springs that are large diameter, stable type which do not require guides or snubbers.

Noise Control/Acoustic Treatment

1. If sound attenuators are used, pack-less types are strongly recommended.
2. Fan powered boxes that have lining exposed to the air stream to have a cleanable surface.

Installation, Fabrication and Construction

Vibration Control

1. Do not make rigid connections between rotating equipment and the building structure that short-circuit vibration isolation systems.
2. Verify mounting systems are not resonant with supported equipment forcing frequencies.
3. Level vibration-isolated equipment while equipment is under full operational load.
4. Install piping sections in reasonable alignment. Using vibration isolation components to correct misalignments is unacceptable.

U. Piping, Valve Pressure Testing and Accessories

Design Criteria

1. Design piping to allow for ample movement and flexibility for expansion and contraction due to temperature changes.
2. Provide a service header for every service entering a building. Provide a shutoff valve in the service header piping immediately upon entry into the building. Install all meters, strainers, pressure reducing valves, backflow preventers, major branch connections, etc. at the service header. Provide bypass connections at the service header so that service to the building is continuous when maintenance is performed on the various components.
3. Provide valves to permit isolation of portions of the building piping systems for maintenance, alterations, and repair work without shutting down entire systems.
4. Provide individual shutoff valves to isolate all equipment from the piping system including pumps, coils, fixtures, fume hoods, bio-safety cabinets, and autoclaves.
5. The following table lists typical piping systems with its corresponding symbol, and pipe codes to reference subsequent Products, Materials and Equipment tables.
6. Example: Potable Cold Water; symbol CW, and pipe code P-1
 - a. Pipe code table P-1 lists a maximum operating pressure of 100 lb/in² and maximum operating temperature of 70° F.
 - b. Facilities Services Design Standard – Mechanical - Plumbing Pressure Testing lists the recommended test pressure of 150lb/in². Facilities Services Design Standard – Mechanical - Water Treatment and Flushing lists the recommended cleaning method of water flush.

Piping System	Symbol	Pipe Code	Pipe Test Method	Test Pressure, lb/in ² gage
Acid Resistant Vent	ARV	P-3	Hydrostatic	(1)
Acid Resistant Waste	ARW	P-3	Hydrostatic	(1)
Carbon Dioxide	CO2	P-1	Pneumatic	1.5 x max. (2)
Central Cooling Water	CCW	P-4	Hydrostatic	250
Coil Condensate	CD	P-1	Hydrostatic	60
Compressed Air (Laboratory)	A	P-1	Pneumatic	150
Compressed Air (Pneumatic)	CA	P-1	Pneumatic	150

Condenser Water	CNDW	P-1	Hydrostatic	60
Fire Protection	F	P-10	(3)	(3)
Heating Hot Water	HHW	P-1	Hydrostatic	1.5 x max.
Helium Recovery	HR	P-1	Pneumatic	1.5 x max. (2)
Irrigation, Inside Building	I	P-1	Hydrostatic	150
Irrigation, Outside Building	I	P-9		
Laboratory Cold Water	LCW	P-1	Hydrostatic	150
Laboratory Hot Water	LHW	P-1	Hydrostatic	150
Laboratory Hot Water Circulation	LHWC	P-1	Hydrostatic	150
Laboratory Vacuum	LV	P-1	Pneumatic	100
Lake Water	LW	P-9	Hydrostatic	1.5 x max. (2)
Medical Gas	MG	P-8	Pneumatic (4)	(4)
Medical Vacuum	MV	P-8	Pneumatic (4)	(4)
Natural Gas	G	P-5	Pneumatic (4)	8
Nitrogen	N	P-1	Pneumatic	1.5 x max. (2)
Oxygen	O	P-8	Pneumatic (4)	(4)
Potable Cold Water	CW	P-1	Hydrostatic	150
Potable Hot Water	HW	P-1	Hydrostatic	150
Potable Hot Water Circulation	HWC	P-1	Hydrostatic	150
Process Chilled Water	CHW	P-1	Hydrostatic	1.5 x max.
Propane	P	P-5	Pneumatic	8
Refrigerant Liquid	RL	P-7	Pneumatic	350
Refrigerant Suction	RS	P-7	Pneumatic	125
Reverse Osmosis/De-ionized Water (High Purity)	DI	P-6	Hydrostatic	150
Roof Drain (Rain Leader)	RD	P-2	Hydrostatic	(1)

Sanitary Vent	V	P-2	Hydrostatic	(1)
Sanitary Sewer	SS	P-2	Hydrostatic	(1)
Sea Water	SW	P-9	Hydrostatic	1.5 x max. (2)
Steam (Low Pressure)	LPS	P-4	Hydrostatic	25
Steam (Medium Pressure)	MPS	P-4	Hydrostatic	90
Steam (High Pressure)	HPS	P-4	Hydrostatic	280
Steam Condensate	CNDS	P-4	Hydrostatic	1.5 x max.
Storm Drain	SD	P-2	Hydrostatic	(1)
Tempered Potable Water (Safety Shower/Eyewash)	TW	P-1	Hydrostatic	150
Trap Primer	TP	P-1	Hydrostatic	150
Well Water	WW	P-9	Hydrostatic	1.5 x max. (2)

Notes:

- (1) In accordance with UPC – Min. 10 ft. head.
- (2) 1.5 x Maximum Operating Pressure.
- (3) Refer to NFPA and Environmental, Health & Safety - Fire Protection System section for information.
- (4) Refer to NFPA for additional information.

Design Evaluation

Products, Material and Equipment

Pipe

1. Use industry standards for piping systems specified and comply with the following additional requirements:
2. The following tables list the typical service piping, standard operating pressures and temperatures, recommended testing pressures.

PIPE CODE P-1

Service	Max Operating Pressure lb/in ² gage	Max Operating Temp Deg F
Carbon Dioxide (CO)	Varies	-
Coil Condensate (CD)	40	60
Compressed Air – Laboratory (A)	100	100
Compressed Air – Pneumatic (CA)	100	100
Condenser Water (CNDW)	40	85
Heating Hot Water (HHW)	Varies	190
Helium Recovery (HR)	Varies	-
Irrigation, Inside Building (I)	100	70
Laboratory Cold Water (LCW)	100	70
Laboratory Hot Water (LHW)	100	160
Laboratory Hot Water Circulation (LHWC)	100	160
Laboratory Vacuum (LV)	-29 in-Hg	100
Nitrogen (N)	Varies	-
Potable Cold Water (CW)	100	70
Potable Hot Water (HW)	100	160
Potable Hot Water Circulation (HWC)	100	160
Process Chilled Water (CHW)	Varies	60
Tempered Potable Water (TW)	100	80
Trap Primer (TP)	100	70
Sizes	½-inch and larger	

Pipe	<p>Above grade: Copper Type L or stainless steel; Below grade: Copper Type K or ductile iron; CNDW, CHW & HHW above grade: 2½-inch and larger, black steel. Schedule 40 Compressed air piping in the tunnels: Schedule 40, black steel, welded, for larger than 2 inch pipe size and schedule 80, black steel, threaded for 2 inch and smaller pipe size. Irrigation outside: See remarks. Nitrogen piping: Clean all fittings/joints for medical gas service per NFPA 99; Mechanical joints are okay for copper and stainless steel water service piping.</p>
Wall Thickness	Standard Weight
Valves	Single piece, full flow ball style. Valves to have a packing nut independent of the handle.
Remarks	<p>Irrigation: Refer to Civil – Irrigation section. LV: Connect branch piping section outlet to top of main. Nitrogen piping system to be brazed under a nitrogen purge. Copper press fitting pipe joining systems okay on CW, LCW, HW, and LHW piping Other mechanical joints okay only for 2-1/2” and larger CW, LCW, CHW, HHW, CNDW and F piping</p>

PIPE CODE P-2		
Service	Max Operating Pressure lb/in ² gage	Max Operating Temp Deg F
Roof Drain (RD)	N/A	N/A

Sanitary Vent (V)	N/A	N/A
Sanitary Sewer (SS)	N/A	N/A
Storm Drain (SD)	N/A	N/A
Sizes	All	
Pipe	Above grade: Cast Iron CISPI 301, no hub; Below grade: Cast Iron CISPI 301, no hub with extra heavy coupling or hub & spigot. Roof drains: Cast iron.	
Wall Thickness	Standard Weight	
Remarks	Above grade force main & force main-vent same as pipe code P-4. Minimum test pressure: 125 lb/in ² . Below grade: Refer to Civil sections for utilities.	

PIPE CODE P-3		
Service	Max Operating Pressure lb/in ² gage	Max Operating Temp Deg F
Acid Resistant Vent (ARV)	N/A	N/A
Acid Resistant Waste (ARW)	N/A	N/A
Sizes	All	
Pipe	Above grade: Polypropylene; pigmented, flame retardant Below grade: Polypropylene; pigmented, non-flame retardant	
Wall Thickness	Schedule 40	
Remarks	Above grade: Fusion joints. Below grade: Fusion joints. Within laboratory casework (accessible): Mechanical joints allowed at the connection to the plumbing fixture.	

PIPE CODE P-4		
Service	Max Operating Pressure lb/in2 gage	Max Operating Temp Deg F
Central Cooling Water (CCW)	200	70
Steam (LPS)	15	259
Steam (MPS)	60	338
Steam (HPS)	185	388
Steam Condensate (CNDS)	Varies	-
Sizes	All	
Pipe	Black steel	
Wall Thickness	LPS and CCW, larger than 12 inch Standard Weight; LPS, MPS, HPS and CCW, 2-1/2 inch to 12 inch Schedule 40; LPS, MPS, HPS and CCW 2 inch and smaller Schedule 80; CNDS, Schedule 80.	
Valves	Campus utility building isolation valves 2 1/2 -inch and larger for CCW, HPS, MPS and LPS service to be triple offset or quadruple offset high performance butterfly valves, see remarks. At CCW control valves, provide DeltaPValve by Flow Control Industries, no substitutions. Inside the building CCW 2-1/2 inch and larger to be Class 150 or Class 300 butterfly valves. CCW 2 inch and smaller to be Class 150 or Class 300 ball valves or rising stem gate valves. HPS, MPS, LPS and CNDS to be Class 150 or Class 300 rising stem gate valves.	
Remarks	2-inch and smaller: Threaded forged fittings;	

	<p>2½-inch and larger: Butt weld type forged fittings;</p> <p>All steam raised faced flanges, with spiral wound gasket.</p> <p>High performance butterfly valves to be Class 150 or Class 300, triple offset or quadruple offset, steel, lugged style, and gear operated by TYCO, Vanessa; WEIR, Tricentric; or QUADAX VALVES, Inc., no substitutions.</p> <p>Specify 300# or higher rated fittings where Schedule 80 piping is used.</p>
--	---

PIPE CODE P-5		
Service	Max Operating Pressure lb/in ² gage	Max Operating Temp Deg F
Natural Gas (G)	5	-
Propane (P)	5	-
Sizes	All	
Pipe	Black steel	
Wall Thickness	Schedule 40	
Remarks	<p>Above grade: 2-inch and larger butt-welded fittings;</p> <p>2-inch and smaller threaded fittings allowed.</p> <p>Below grade: Refer to Civil sections for utilities.</p> <p>See EH&S Laboratory Safety Design Guide regarding lab emergency gas shut-off valves.</p>	

PIPE CODE P-6

Service	Max Operating Pressure lb/in2 gage	Max Operating Temp Deg F
Reverse Osmosis/De-ionized Water (DI)	100	70
Sizes	All	
Pipe	Polypropylene – non-pigmented	
Wall Thickness	Schedule 40	
Valves	Union body, full port, ball style	
Remarks	Electrofusion joints for distribution piping. IR butt weld joints allowed at generation skids. Piping to be continuously supported.	

PIPE CODE P-7		
Service	Max Operating Pressure lb/in2 gage	Max Operating Temp Deg F
Refrigerant Suction (RS)	High Side: 250	150
Refrigerant Liquid (RL)	Low Side: 90	70
Sizes	½-inch and larger	
Pipe	Copper, ACR type	
Wall Thickness	Standard Weight	
Remarks	No flared connections and fittings. Braze piping under nitrogen purge.	

PIPE CODE P-8		
Service	Max Operating Pressure lb/in2 gage	Max Operating Temp Deg F
Medical Gas (MG)	Varies	150

Medical Vacuum (MV)	Varies	70
Oxygen (O)	Varies	-
Sizes	½ inch and larger	
Pipe	Medical Gas and Oxygen: Copper, wall thickness per Code, Medical Vacuum: Copper Type L, Piping to be specially prepared and labeled for medical service, oxygen and vacuum.	
Wall Thickness	Standard Weight	
Remarks		

PIPE CODE P-9		
Service	Max Operating Pressure lb/in ² gage	Max Operating Temp Deg F
Irrigation, Outside Building (I)	100	70
Lake Water (LW)	Varies	70
Sea Water (SW)	Varies	70
Well Water (WW)	Varies	70
Sizes	½-inch and larger	
Pipe	Polypropylene or CPVC or PVC if not exposed. Sea water, outside: HDPE	
Wall Thickness	Schedule 40	

PIPE CODE P-10		
Service	Max Operating Pressure lb/in ² gage	Max Operating Temp Deg F

Fire Protection (F)	-	-
Sizes	See remarks.	
Pipe	See remarks.	
Wall Thickness	See remarks.	
Remarks	Refer to NFPA and Environmental Health & Safety Design Guide – Sprinkler Protection & Standpipes section.	

Pipe Insulation

1. Provide metal jackets for all new piping insulation located in outside air intakes, building plenums, and on all piping insulation less than 8 feet above the finished floor in mechanical rooms.

Valves

1. Provide valves with flanged, grooved or threaded ends. Valves may have solder ends for 2-inch and smaller copper piping. See Mechanical - Piping section.
2. Provide gate valves with rising stem and union bonnet for 2-inch and smaller.
3. Provide ball valves for 2-inch and smaller pipe and butterfly valves for 2½-inch and larger pipe.
4. Balancing valves to be globe type with ports and graduated scale. Do not use balancing valve as an isolation valve. All balancing valves to be sized based on the appropriate flow within the range of the valve not the service pipe size.
5. Plug valves larger than 2-inch size to be lubricated type.
6. Provide check valves on each individual closed loop makeup water system.

Strainers

1. Provide wye type strainers in 2-inch and smaller piping.
2. Provide basket type strainers in piping larger than 2-inch, except for steam piping.
3. Provide wye type strainers in steam piping.
4. Match strainer body material with piping material.
5. Provide strainer screens with a free area not less than three times the free area of the pipe line. Perforations to be 1/16-inch size. Provide stainless steel screens in steam strainers. Provide brass screens in all other strainers.

Installation, Fabrication and Construction

Pipe and Fittings

1. Provide unions or flanged connections at equipment for maintenance and repair.

2. Provide insulating nipples or flanges between to connect piping with dissimilar metals.
3. Provide welding outlets where branch piping is smaller than the main. Provide welding tees for all other cases.

Pipe Sleeves

1. Provide sleeves large enough to allow insulated piping pass through without disrupting the insulation.
2. Provide elastomer wall penetration modular seals on all sleeves through exterior walls below grade.
3. Provide UL Listed fire-stopping material on all sleeves through fire rated floors and walls.

Valves

1. Install valves with the stem vertical. When this is not possible, they may be installed rotated but never less than horizontal under any circumstance.
2. Provide isolation valves at each floor for all services.
3. Install isolation valves staggered where they come out from a pipe shaft so they are completely and conveniently accessible.
4. Install valves with adequate room to permit removal of the bonnet, disk, and trim without removing the valve from the line.
5. Provide globe valves where throttling is required, except for balancing valves.
6. Provide balancing valves at all pumps, main pipe branches, and all system coils. Balancing valves at VFD-driven pumps may be omitted if means for measuring flow are provided (e.g. Venturi taps with flow measuring kit).
7. Triple Duty valves are not allowed.
8. Discuss the sizing of balancing valves for small coils (less than 1 gpm) with Engineering Services.

Strainers

1. Provide a ball valve and hose-end adapter for blow-down on all wye strainers, except use gate valve on steam and condensate strainers.
2. Provide strainers ahead of automatic control valves, steam traps, and in main service piping to buildings. Those steam traps provided for a device having an automatic control valve do not require strainers.

Headers

1. Space components apart by at least two pipe diameters between flanges.
2. Locate header assemblies approximately 4 feet above the floor.

Piping Pressure Tests

1. Pressure test all pipe systems.
2. Test piping after all associated fittings, and valves have been installed.

3. Demonstrate to an Owner representative for each pressure testing. Leave the pipe exposed and do not insulate until the associated pipe section has been signed off by an Owner representative.
4. Repair leaks discovered during pressure testing. Retest failed sections of piping until satisfactory results are obtained.
5. Maintain a set of drawings for recording and sign-off of each tested section.
6. After each day of testing, submit to the Owner a copy of the paperwork recording the raw test data, designating the piping system and Pipe Code, and comparing the allowable and actual results.

Pipe Testing Methods

1. Hydrostatic pressure testing: Use clean, fresh city water for test. On compressed gas piping remove water from piping systems after testing and dry by blowing dry, oil-free air or nitrogen through lines.
2. Pneumatic pressure testing: Perform testing with dry, oil-free air or nitrogen on piping systems.
3. The following table lists typical piping systems and the corresponding recommended test method and test pressure.

Piping System	Pipe Code	Test Method	Test Pressure, lb/in ² gage
Central Cooling Water	P-4	Hydrostatic	250
Condenser Water	P-1	Hydrostatic	60
Heating Hot Water	P-1	Hydrostatic	1.5 x max.
Process Chilled Water	P-1	Hydrostatic	1.5 x max.
Refrigerant Liquid	P-7	Pneumatic	350
Refrigerant Suction	P-7	Pneumatic	125
Steam (Low Pressure)	P-4	Hydrostatic	25
Steam (Medium Pressure)	P-4	Hydrostatic	90
Steam (High Pressure)	P-4	Hydrostatic	280
Steam Condensate	P-4	Hydrostatic	1.5 x max.

V. Pumps

Basis of Design

This section applies to the selection and installation of pumps for hot and chilled water circulation, condenser water systems, sump and steam condensate return systems.

Design Criteria

1. Locate pumps in mechanical rooms whenever possible and provide easy service accessibility and isolate them to prevent pumping or vibration source noise from disturbing the surrounding occupied areas.
2. Provide pumps that allow installation of a larger impeller to meet future requirements whenever possible.
3. Provide stand-by pumps when shutdowns cannot be tolerated for repairs and maintenance. For example, condensate pump stations, sewer lift stations, and primary pumping loops.
4. Provide pumps that operate at 1800 rpm.
5. Provide centrifugal-type pumps where the shutoff head is not more than 25% greater than the operating head.
6. Provide check valves in the pump discharge piping when pumps are operating in parallel, standby, or whenever a reverse flow may occur.
7. Provide "lead-lag" start controls for dual pumps. Provide the ability to manually alternate the pumps on a "lead" start.
8. Obtain discharge head information for condensate pumps from the UW Project Manager. There are locations on campus at an elevation lower than the Power Plant. Other locations are gravity return to the Power Plant hot well.
9. Provide duplex pumps with standby power for steam condensate pumps stations and sewer lift stations.
10. Ensure that a copy of each pump curve with design conditions plotted is included in the Operations and Maintenance manual.

Products, Material and Equipment

1. Provide a pump that is a complete, integrated unit consisting of pump, motor, shaft, coupling, frame and base as manufactured at the factory.
2. Pumps: Centrifugal, end suction or horizontal split case type.
3. Provide close-coupled pumps up to 1 hp; otherwise provide a frame-mounted type.
4. In-line circulators may be used when they can be adequately supported and are easily accessible.
5. Provide frame-mounted, not close coupled, chilled water pumps, so that the entire casing and connections may be completely insulated.
6. Provide mechanical seals on all pumps, suitable for the intended service.
7. Provide certification from the pump manufacturer that the mechanical seals for pumps are suitable for the maximum expected temperature and chemical treatment used.

8. Provide pressure gauges upstream and downstream of pump between pump and isolation valves.
9. Provide an air vent in the casing of 1 HP and larger pumps.
10. Provide vertical shaft-type sump pumps with the motor located above the sump.
11. Condensate pumps: Preferred floor mounted, cast iron casing type. Select pump and pump seals for 210° F water without flashing for large condensate applications.

Installation, Fabrication and Construction

1. Specify each pump with separate balancing valves in the discharge piping so the design flow rate may be set.
2. Provide each pump with check valves, isolating valves and unions or flanges for easy service removal.
3. Provide all pumps with inlet strainers as part of the piping or pump inlet accessories.
4. Grout pump base to the concrete equipment pad or inertia base for floor mounted pumps.
5. For floor mounted condensate pumps, provide a sight glass and vent. Terminate vent to the outdoor. If an outdoor termination is not convenient, pipe the vent a minimum of 4 feet vertically and terminate at a drain.
6. Provide isolation valves between condensate pumps and condensate receiver.
7. Minimize pipe/pump flexible connections.
8. Verify pump alignment and submit alignment data.

W. Testing, Adjusting and Balancing

Design Criteria

1. Check with the UW Project Manager to see if the TAB services are to be provided by the Contractor as part of the construction contract commissioning service or to be hired directly by the UW under a separate contract.
2. Give special consideration to the TAB process during the design so that a technician can test and analyze the particular installation and properly balance the system to obtain the greatest system efficiency and comfort level. It is important that balancing capability be designed into the system.
3. On systems with variable frequency drives (VFD) the fan and pump design performance needs to be accomplished with the VFD operating at 55 to 58 HZ as the standard VFD arrangement unless specifically directed otherwise by the contract documents. Provide the necessary sheave replacements and pump impeller trim to achieve this arrangement.
4. Specify that Testing Adjusting and Balancing is performed in accordance with current NEBB or AABC requirements. Balancers must be affiliated by qualification with NEBB or AABC.
5. Specify the scope of Testing, Adjusting, and Balancing in the project contract documents.

Construction Submittals

Balance Report submittals

Preliminary submittal

1. Draft report for review by the A/E, Commissioning Agent, and UW Engineering Services that includes the following:
 - a. A list of items that prevents the balancer from providing a full and complete balance or testing.
 - b. Narratives that describe all problem areas that may require major construction or design changes.
 - c. Narratives that describe the building systems and control systems to demonstrate comprehension of system operation, including system diversity.
 - d. The balancing agenda which reiterates the scope of the balancing work and the intended order of activity.
 - e. Sample balancing data sheets

Final submittal

1. Certified Testing Adjusting and Balancing report that includes the following:
 - a. Completed balancing data sheets.
 - b. Drawings annotated to indicate inlet and outlet numbering that corresponds to the balancing data sheets.

- c. Narratives that describe the building systems and control systems including system diversity.
- d. Narrative description of those items not conforming to the contract requirements.

X. Water Treatment and Flushing

Design Criteria

1. Provide cooling tower water treatment controller per [Preferred Vendors](#) list.
2. Provide catalog cut sheets including SDS data sheets for chemicals used. List the name and chemical content of all additives, the amount to be added to each piping system, the total volume of each system and schedule of chemical feed.
3. Submit a flushing and water treatment plan for each system. Include data sheets for equipment to be provided and parameters set for the procedure; such as media used for flushing, pressure, velocity, temperature, and duration.
4. Conduct and submit initial water quality analysis to ensure the onsite water supply is within reasonable expected conditions and as a basis for the overall chemical treatment program.
5. Provide polypropylene glycol for systems subject to freezing. Submit a report of the manufacturer and specific chemical contents of all additives, the amounts added, the total volume of the system, and the rated freezing temperature for the specified concentration.
6. Provide a schedule indicating total volume of each system and targeted tolerable range of test results.
7. Provide a list of piping systems requiring chemical treatment and specify treatment.
8. Chemical treatment report to include pipe volume for each hydronic system. In addition, the report is to include the total bacteria, corrosion rates and meter readings.
9. Provide a pot feeder, a coupon rack and a make-up water meter for each hydronic system, (except chilled water system not decoupled from the CCW)

Installation, Fabrication and Construction

General

1. Submit a flushing and water treatment plan and integrate the tentative schedule in the construction outlook plan.
2. Maintain a set of drawings on-site for recording and sign-off of each flushed and/or treated section or system. All flushing/cleaning and treatment to be observed and documented with results approved by an Owner representative.
3. After each day of flushing/cleaning and treatment, submit to the Owner a copy of the paperwork recording the raw data, designating the piping system and Pipe Code, and comparing the allowable and actual results.
4. Central Cooling Water is treated by the University at the Central Power Plant and West Campus Utility Plant. For CCW treatment, fill the CCW system with clean water and notify Engineering Services and the Central Power Plant of the system startup date and total system volume.
5. For closed-loop hydronic systems, label total water volume (in gallons) and glycol concentration (in %) near pot feeder.

Flushing/Cleaning and Treatment Methods

1. Special procedures or temporary modifications may be required to ensure all parts of the system are flushed and receive chemical treatment. Pay particular attention to piping dead legs and back-up equipment (back-up chiller, back-up pumps, etc.). Return all systems to intended operating conditions after successful completion of the procedure.
2. Hydrostatic or water flush: Use clean, fresh city water. On gas piping, remove water from the entire systems after flushing and use the following pneumatic cleaning method to dry the system.
3. Pneumatic cleaning: Blow clean, dry and oil-free air or nitrogen through the system.
4. Water flush: Flush piping with water at a velocity of 6 ft/s until effluent is clean and contains no visible particulate matter. Provide flow measurement in flushing water supply line to be used as basis for verification of flow velocities in piping system. Clean all strainers after flushing.
5. For CCW, perform the system pressure test and flushing in the presence of Engineering Services. CCW cannot be used for flushing. Provide temporary pumps, to flush the system with water at a velocity of 5 to 6 feet per second. Piping to be filled with clean water after flush and prior to opening valves. Notify Power Plant personnel to open the valves to the main CCW system after approval by Engineering Services
6. Extension of water treatment program: Continue the treatment program for a period of one year following the date when the system is put into intended normal operation. The extended program includes monthly water quality tests, reports, and scheduled chemical feed to maintain water quality within tolerable ranges.
7. The following table lists the typical piping system, pipe code and corresponding recommended cleaning method:

Piping System	Cleaning Method
Acid Resistant Waste	-
Carbon Dioxide	Pneumatic
Central Cooling Water	Water Flush
Coil Condensate	Water Flush
Compressed Air (Laboratory)	Pneumatic
Compressed Air (Pneumatic)	Pneumatic
Condenser Water	Water Flush
Fire Protection	(1)
Heating Hot Water	Water Flush
Helium Recovery	Pneumatic

Piping System	Cleaning Method
Irrigation	Water Flush
Laboratory Cold Water	Water Flush (3)
Laboratory Hot Water	Water Flush (3)
Laboratory Hot Water Circulation	Water Flush (3)
Laboratory Vacuum	Pneumatic
Lake Water	Water Flush
Medical Gas	Pneumatic (2)
Medical Vacuum	Pneumatic (2)
Natural Gas	Pneumatic (2)
Nitrogen	Pneumatic
Oxygen	Pneumatic (2)
Potable Cold Water	Water Flush (3)
Potable Hot Water	Water Flush (3)
Potable Hot Water Circulation	Water Flush (3)
Process Chilled Water	Water Flush
Propane	Pneumatic
Refrigerant Liquid	Pneumatic
Refrigerant Suction	Pneumatic
Reverse Osmosis/De-ionized Water (High Purity)	Water Flush
Sea Water	Water Flush
Steam (Low Pressure)	Water Flush
Steam (Medium Pressure)	Water Flush
Steam (High Pressure)	Water Flush
Steam Condensate	Water Flush
Tempered Water (Safety Shower/Eyewash)	Water Flush
Trap Primer	Water Flush

Piping System	Cleaning Method
Well Water	Water Flush

- (1) Refer to NFPA and Environmental, Health & Safety - Fire Protection System section for information.
- (2) Refer to NFPA for additional information.
- (3) Refer to City/County Department of Public Health for cleaning, disinfection, bacteriological testing, and additional information. Contact Owner prior to testing.

Preferred Vendors and Products - Mechanical

Product	Manufacturer A	Manufacturer B	Manufacturer C	Remarks
CCW Coils & Heat Exchangers	Delta P Valves			No substitutions
Bypass Relief Valve	Cash Acme	Kunkel		Or approved equal.
Freeze Protection	Dowtherm HD			Or approved equal.
CCW valves	TYCO, Vanessa	Weir, Trientric	QUADAX VALVES Inc.	No substitutions
Steam Valves	TYCO, Vanessa	Weir, Trientric	QUADAX VALVES Inc.	No substitutions
VFDs	Allen Bradeley Powerflex 70	Danfoss VLT 20X	Yaskawa GPD 506	No substitutions
Steam Condensate	See Standard Specifications			No substitutions
CCW BTU	See Standard Specifications			No substitutions
CCW Chilled Water Insertion	See Standard Specifications			No substitutions
Deduct Water - Cooling Tower, Grey Water	See Standard Specifications			No substitutions
Deduct Water - Irrigation	See Standard Specifications			
Natural Gas - Main Utility, 2" and Larger	See Standard Specifications			
Natural Gas - Main Utility, up to 1.5"	See Standard Specifications			No substitutions
Natural Gas - Submeter	See Standard Specifications			No substitutions
Water Treatment Controller	Nalco 3DTRASAR			No substitutions
DDC control	Siemens Landis Division	Johnson Controls (Bothell)	Alerton by ATS Automation	Sole sourced/No substitution.
Wall sensors mounting hardware	Allen	Bristol		Or approved equal.
Actuated dampers	American Warming and Ventilation	Ruskin	Greenheck	Or approved equal.
Refrigeration Leak Detection - Control Pnl	Honeywell 301EM control panel			No substitutions
Refrigeration Leak Detection - Control Pnl	Honeywell 301EMRP-20 remote pnl			No substitutions
Refrigeration Leak Detection - Sensor	Honeywell 301IRFS gas detector			No substitutions
Gas Monitors - CO and NO2 sensors for Park	Honeywell E3Point			No substitutions